



Owner's Manual

LSV30120BP
LS5000B leg bundle
LS5001B post bundle
LS5012BP cradle bundle 120"
LS5003B spreader bundle
LS5004BP bunk bundle
LS5005BP accessory box
LS2005B wheel

LSV40120BP
LS5000B leg bundle
LS5001B post bundle
LS5012BP cradle bundle 120"
LS5003B spreader bundle
LS5004BP bunk bundle
LS5005BP accessory box
LS5007B diagonal bundle
LS2005B wheel

LSV50120BP
LS5000B leg bundle
LS5021B post bundle
LS5022B cradle bundle 120"
LS5003B spreader bundle
LS5004BP bunk bundle
LS4005BP accessory box
LS5007B diagonal bundle
LS2005B wheel

READ CAREFULLY - FAILURE TO FOLLOW INSTRUCTIONS AND SAFETY RULES MAY RESULT IN SERIOUS INJURY

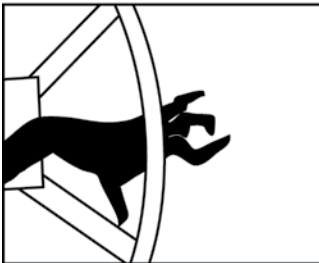

WARNING
DO NOT ATTEMPT TO STOP SPINNING WHEEL.
Serious personal injury could result.
Lift Wheel must be turned clockwise for lifting.
NEVER raise lift by turning wheel counterclockwise.
Doing so will result in an uncontrolled spin down,
which could lead to cable failure and serious injury.
Z117

CAUTION
DO NOT CRANK PAST STOP POSITION.
When raising lift be aware that when moving components
contact frame you have reached maximum height.
Turning wheel past this point may cause personal injury
and will cause damage to lift that is not covered by warranty.
Z119

WARNING
DO NOT OPERATE THIS HOIST WITHOUT FIRST STUDYING THE OWNER'S MANUAL.
1. Before operating this lift be sure to understand all operating procedures and safety precautions.
2. NEVER operate lift with people on board boat or near any part of lift.
3. NEVER work or play on, around or under lift.
4. NEVER exceed the rated capacity of lift. Doing so may cause lift to fail.
5. Before use visually inspect SHEAVES and CABLE for wear or fraying. Follow proper maintenance procedures.
Failure to follow these procedures could cause lift to fail and result in death or
serious personal injury.
Z116

# STEP 1

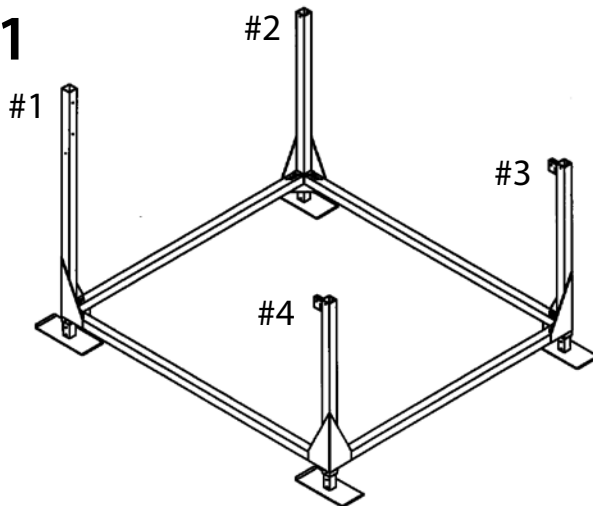

Mainframe Posts (A,B,P,R)*	4
Legs (S)	4
120" Mainframe Spreaders (N,O)	4
Bolt Package Step 1	1

\* denotes letter on exploded view

## 1.1 attach legs

Slide 4 legs into the 4 mainframe posts using:

- 4 - 3/8" x 4" bent clevis pins
- 4 - hairpin cotters

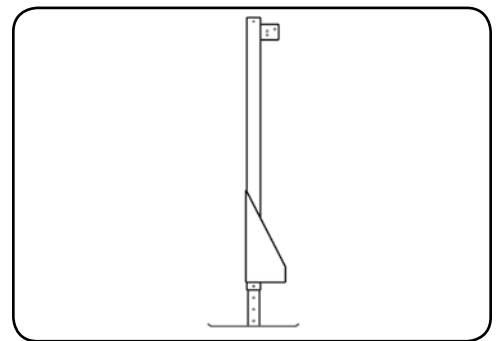

## 1.2 arrange Mainframe Posts

Stand all 4 posts on a flat area, arranged as shown above.

## 1.3 attach Side Mainframe Spreader Tubes

Position one 120" Mainframe Spreader Tube between Post #1 and #4. Bolt in place using:

- 2 - 3/8" x 5" hex bolts
- 4 - 3/8" flat washers
- 2 - 3/8" nylon lock nuts

at each post. Repeat with other 120" Mainframe Spreader between Post #2 and #3.

NOTE: The Mainframe Spreader Tubes are 120" long with the large slots in each end.

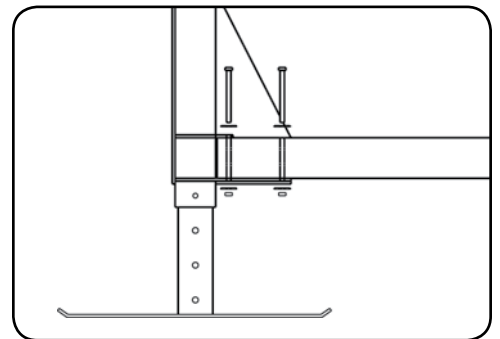

## 1.4 attach Front/Rear Mainframe Spreader Tubes

Position one Mainframe Spreader Tube between Post #1 and #2. This is the front of the lift. Bolt in place using:

- 2 - 3/8" x 4-1/2" hex bolts
- 2 - 3/8" flat washers
- 2 - 3/8" nylon lock nuts

at each post. Repeat with other Mainframe Spreader between Post #3 and #4. This is the rear of the lift.

NOTE: On the 30108 and 40108 models the Mainframe Spreaders are 108". On the 30120 and 40120 models the Mainframe Spreaders are 120".

## STEP 2

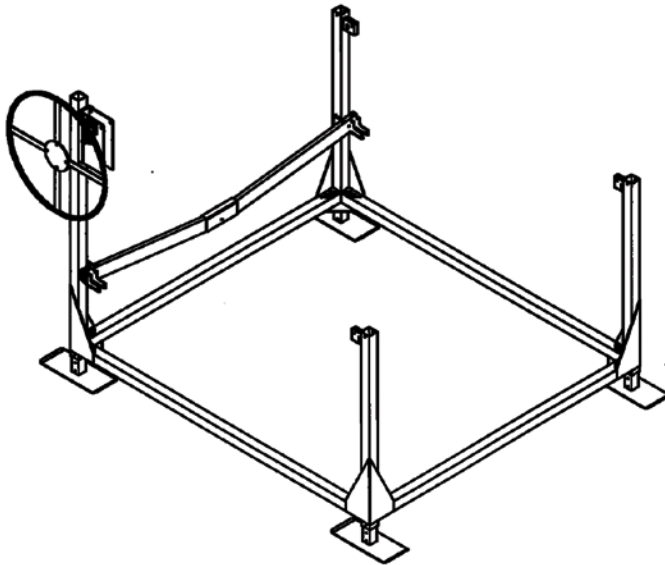

Cradle Front (K)	1
Winch (H)	1
Wheel 41" (I)	1
Wheel Shaft Adapter(I)	1
Bolt Package Step 2	1

### 2.1 attach Winch

Attach winch to Post #1 - the tallest one with:

- 2 - 3/8" x 5" hex bolts
- 2 - large aluminum washers
- 2 - 3/8" nylon lock nuts

Be sure to place the washers under the heads of the bolts on the outside of the post.

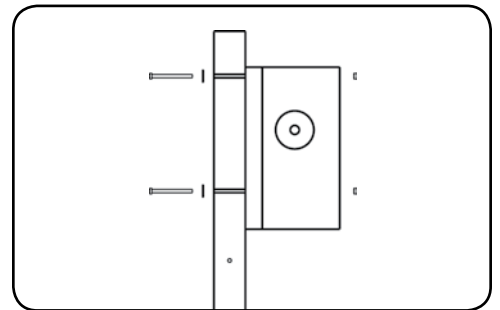

### 2.2 attach Wheel

Remove the 4 Carriage Bolts from the Wheel Mounting Plate. Align the 4 holes in the Mounting Plate with the holes on the Shaft Adapter.

Attach using the 4 Carriage Bolts and Locknuts provided.

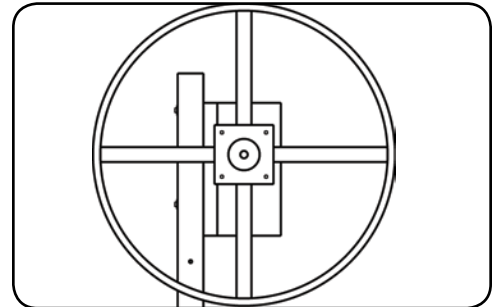

### 2.3 attach Front Cradle

Position the Front Cradle between Post #1 and #2. NOTE: the Front Cradle has a cable with a loop on only one end.

Attach the loop end to Post #2 in the low hole closest to the post with:

- 1 - 1/2" x 2" hex bolts
- 1 - 1/2" nylon lock nuts

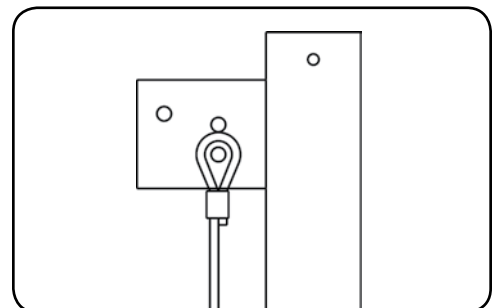

### 2.4 attach Cable

The cable attaches to the black drum at the bottom of the winch. It passes through the hole in this drum and is held in place by a set screw located in the center of the hole. The head of this screw can be reached through a hole that has been placed on the side of the winch. The drum will have to be turned until the set screw appears through this hole. Loosen the screw with the 5/32" Allen Wrench supplied with your lift. Then pass the cable through the hole in the drum until 1/4" of the cable sticks out the other end, and tighten the set screw.

# STEP 3

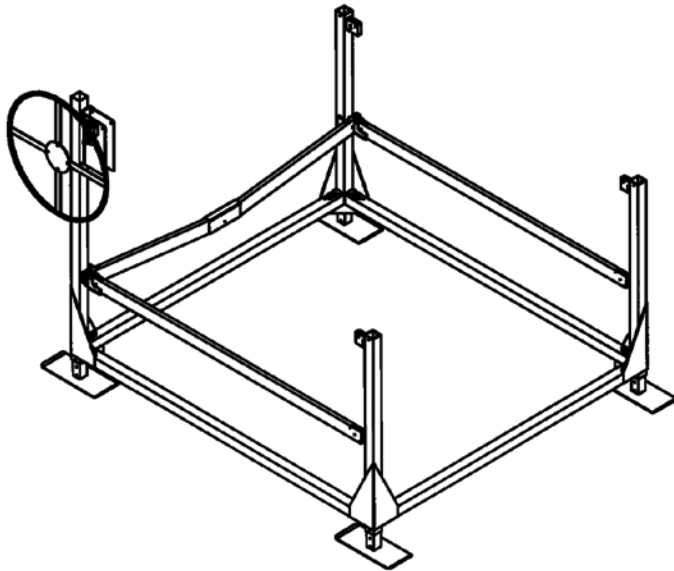

Cradle Spreaders (L)	2
Bolt Package Step 3	1

## 3.1 attach Cradle Spreader

Attach one end of the Cradle Spreader tube to the Front Cradle near Post#1.  
Use:

- 4 - 3/8" x 2-1/2" hex bolts
- 4 - 3/8" nylon lock nuts

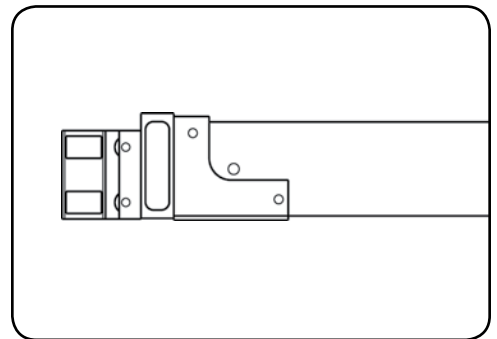

## 3.2 attach Side Cable

Feed the end of the cable that hangs down through the holes in the Main-frame Spreader Tube by Post #1 and pull out the bottom of the lift. Using:  
1 - Shackle

Unscrew the Shackle Pin and put the Shackle through the loop at the end of the cable. Securely thread the pin into the Shackle and tighten to secure the cable.

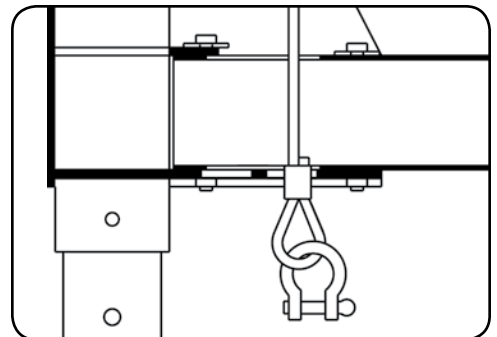

## 3.3 attach Side Cable

Take the opposite end of the cable that comes up out of the Spreader and attach it to the top of Post #4. Use the holes furthest away from the post and attach using:

- 1 - 1/2" x 2" hex bolts
- 1 - 1/2" nylon lock nuts

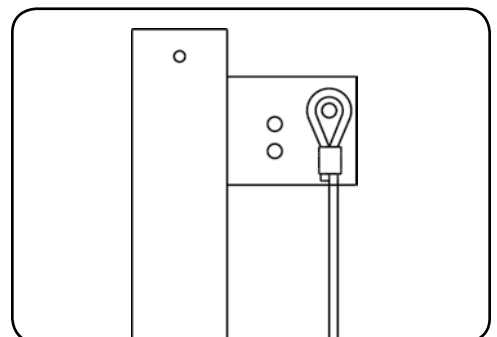

## 3.4 repeat

Repeat for other Cradle Spreader.

# STEP 4

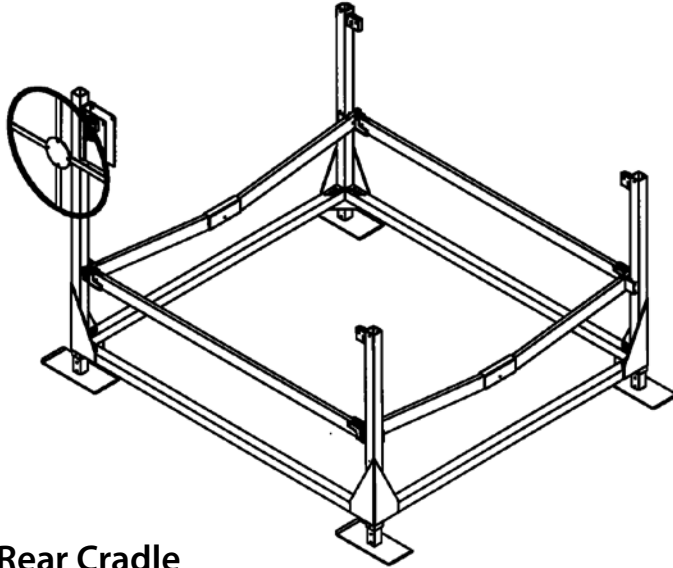

Rear Cradle (Q)	1
Bolt Package Step 4	1

## 4.1 attach Rear Cradle

Set the Rear Cradle on the ends of the Cradle Spreader tubes. Attach to the Spreaders using:

- 4 - 3/8" x 2-1/2" hex bolts
- 4 - 3/8" nylon lock nuts

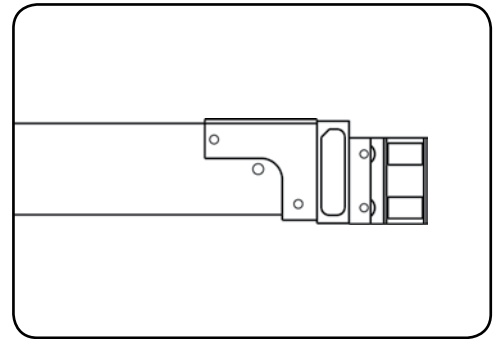

## 4.2 attach Cables at bottom

Feed the two down cable ends through the side Mainframe Spreader Tubes and out the bottom of the lift. Attach using:

- 2 - Shackles

Unscrew the Shackle Pin and put the Shackle through the loop at the end of the cable. Securely thread the pin into the Shackle and tighten to secure the cable.

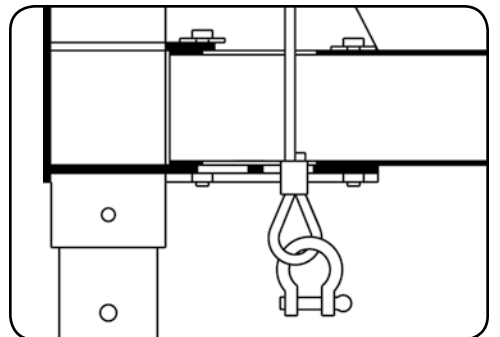

## 4.3 attach Cables at top

Attach the two up ends of the cables to Post #3 and #4. Use the holes closest to the post, starting with both cables in the lowest holes. If the rear cables appear too loose, try moving one cable, or both to the next hole. Bolt in place using:

- 1 - 1/2" x 2" hex bolts
- 1 - 1/2" nylon lock nuts

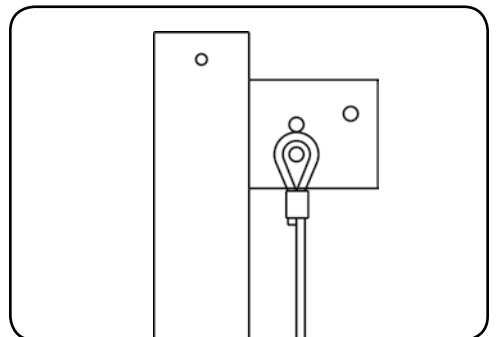

# STEP 5

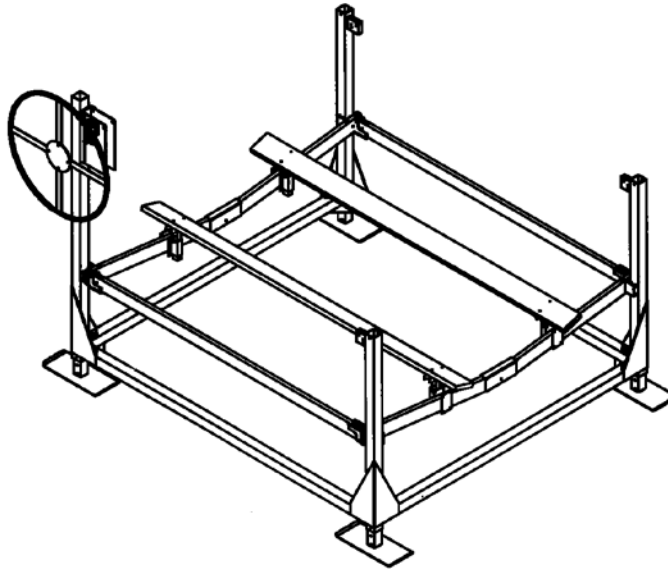

Bunk Assembly (C)	4
Bolt Package Step 5	1

## 5.1 attach Bunks

Attach Bunk Sockets and Bunk Socket Plates making sure to place the sockets towards the inside of the lift.

- 32 – 3/8" x 2-1/2" hex bolts
- 32 – 3/8" nylon lock nuts

Install the Bunks by sliding into the Bunk Sockets and securing with:

- 8 – 3/8" x 2-1/2" clevis pin
- 8 – hairpin cotter

## 5.2 adjust Bunks

Move your lift into the water.

Adjust the height and position of the Bunks so that they cradle your boat and keep the bottom of the boat off the Cradle.

## 5.3 adjust Legs

Adjust the lift Legs so that the lift sits level in the water, within 3" to 6" is acceptable.

## 5.4 install Diagonals (on LSV40120BP only)

Install the Diagonal Brackets by snapping it over the center of the Side Mainframe Spreaders. Bolt the Diagonals from this bracket to the hole at the top of each Mainframe Post with:

- 4 – 3/8" x 1-1/4" hex bolts for center bracket
- 4 – 3/8" x 4-1/2" hex bolts for top of post
- 8 – 3/8" hex locknut

### NOTE

Never over crank the winch. Once the lift has reached its highest point, further cranking will damage the lift.

### NOTE

The wheel needs to thread on and off the shaft to activate the brake. This shaft should be greased yearly to ensure proper operation.

Extreme care should be taken not to cross thread and damage the threads on the wheel hub. This will void your warranty.

## hints

- A. Shallow water ? Remove the adjustable legs to make the lift sit even lower in the water. In this position the Cradle can be placed lower than on any other lift available.
- B. Deep water ? Extension legs are available in 4', 5', and 6' lengths. Call your Dealer for pricing.
- C. The front Cable will last much longer if you grease the first 5' to 8' that goes into the winch.
- D. The winch and brake mechanism will work better if the wheel shaft is greased yearly. This task has been simplified by the addition of a grease fitting on the wheel shaft right behind the red wheel.
- E. Do not overcrank your lift. Be sure to notice the maximum height that your lift will rise to and STOP when you reach that height. Failure to do so will damage your lift.

## important

- A. Grease the winch shaft annually. The red wheel must be able to thread and unthread easily in order for the braking mechanism to work properly.
- B. Your Lakeshore Jet Lift will only protect your personal watercraft if the craft is lifted well above the level of the water. In larger lakes or during storms, large waves may lift the craft from the lift or tip the lift over, causing damage both to the craft and the lift. You must take precautions to protect your craft and lift from these conditions. If your craft suffers damage from high waves, LSP, Inc. will not accept responsibility for such damage.
- C. Inspect your lift often for signs of wear or improper operation. Be aware of normal cranking force. Any increase in cranking force is a sign that something is wrong. DO NOT USE the lift if any parts are worn or damaged, replace immediately.
- D. Pay attention to the condition of your cable. A frayed or rusted cable can lead to failure of the lift. Replace it immediately. Greasing the cable, especially where it enters the winch, can extend its life.
- E. A second caution decal is provided in the accessories box. If after assembly the decal is not easily seen then install the extra decal so that anyone using the lift can read it. NEVER let anyone operate the lift unless they are familiar with all safety rules.
- F. NEVER let anyone play on, around, or under the lift.

## LS5005BP accessory package

BPV30B	Bolt Package V30/40B	1
20852	Bolt Package STEP 5	1
W4	Winch	1
20855	Wheel B Shaft Adapter	1
20676	Bunk Socket	8
20678	Bunk Socket Plate	8
CAPS3535	3-1/2" x 3-1/2" Black Cap	4

## BPV30B bolt package

20848	STEP 1	
Y420	3/8" x 5" hex bolt	16
Y451	3/8" hex lock nut	16
Y452	3/8" flat washer	32
CP1	3/8" x 4" bent clevis pin	4
HPC	1/8" hairpin cotter	4
20849	STEP 2	
Y420	3/8" x 5" hex bolt	2
Y451	3/8" hex lock nut	2
Y508	1/2" x 2" hex bolt	1
Y551	1/2" hex lock nut	1
Y552	large aluminum washer	2
20890	5/32 allen wrench	1
20850	STEP 3	
Y410	3/8" x 2-1/2" hex bolt	4
Y451	3/8" hex lock nut	4
Y508	1/2" x 2" hex bolt	2
Y551	1/2" hex lock nut	2
SHACKLE	3/8" shackle	2
20851	STEP 4	
Y410	3/8" x 2-1/2" hex bolt	4
Y451	3/8" hex lock nut	4
Y508	1/2" x 2" hex bolt	2
Y551	1/2" hex lock nut	2
SHACKLE	3/8" shackle	2
20852	STEP 5	
Y410	3/8" x 2-1/2" hex bolt	16
Y451	3/8" hex lock nut	16
CP	3/8" x 2-1/2" clevis pin	4
HPC	1/8" hairpin cotter	4

## Ten/Two Year Limited Warranty

LSP, Inc. (Seller) warrants the aluminum structure on docks and lifts of its manufacture to be free from defects caused by material or workmanship for ten years from date of purchase. Seller will, at its option, repair or replace any such goods found on examination by Seller to be defective under normal use and service. Upon discovery of any such defect, Buyer must notify Seller in writing of defect and provide proof of purchase. Seller warrants all other materials including cast aluminum parts, mechanical components, hardware, canopy covers, cables, bunks, etc for two years. Components obtained from other manufacturers and used in Seller's products will be covered under the manufacturer's warranty and shall not be the responsibility of the Seller.

Seller's responsibility under this warranty shall be the repair or replacement of defective items. Seller is not liable for incidental or consequential damages of any kind.

Seller shall not be held responsible for repairs or modifications to its docks or lifts unless authorization has been obtained from Seller. This warranty does not cover damage caused by incorrect assembly or adjustments, overloading, improper use, neglected maintenance, alterations, or damage caused by accident, environmental factors (chemicals, tree sap, salt, etc), or acts of God (rainstorms, windstorms, tornadoes, etc).

# LSV30/40120BP

Lakeshore Lift Vertical Pontoon, 3000/4000 lb. cap., 120" Beam, 52" Lift Height.

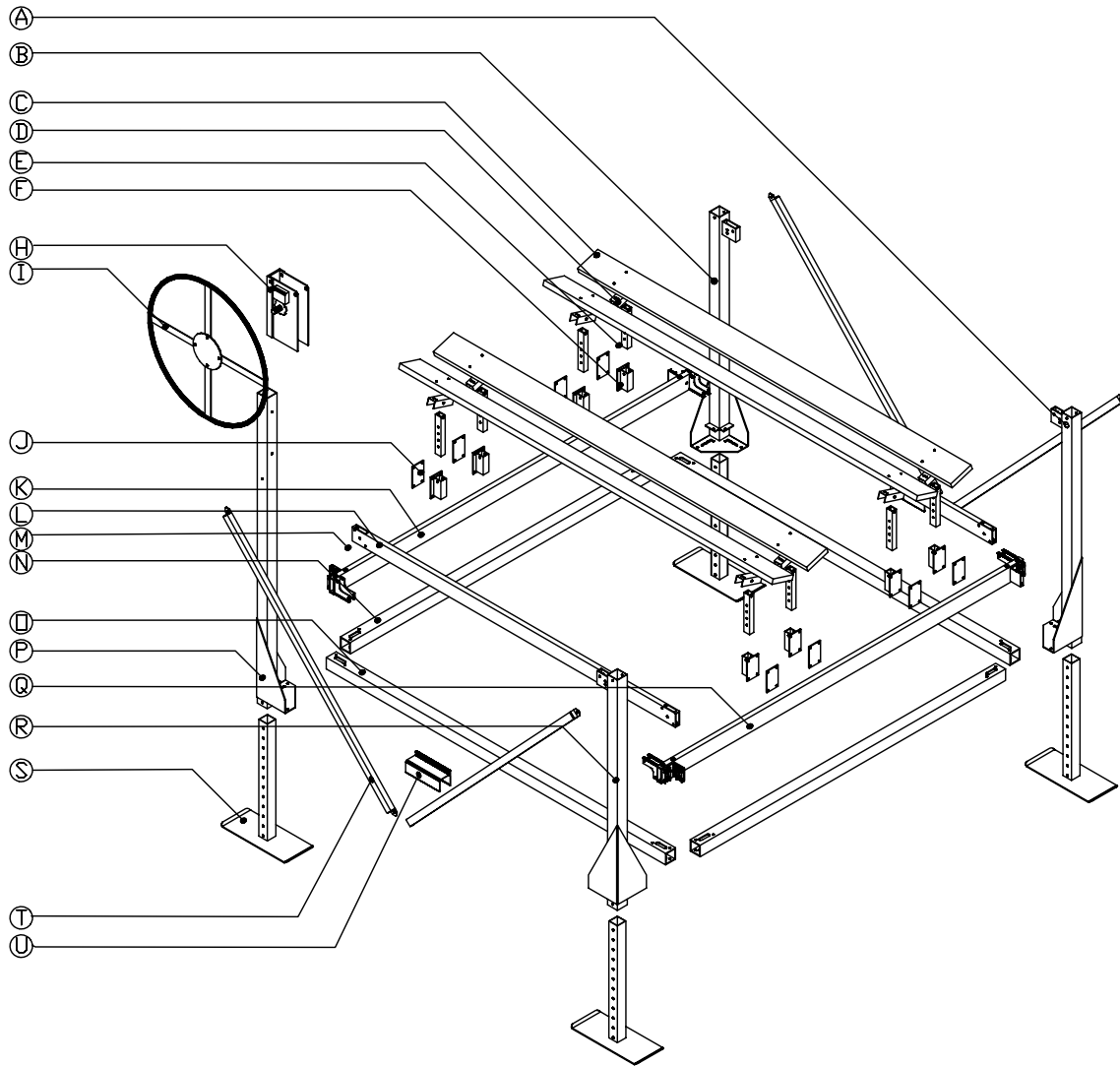

## PARTS LIST LSV30120BP

ref.	part no.	part name	qty.
A	20834	Mainframe Post #3	1
B	20833	Mainframe Post #2	1
C	BUNK4000B	Bunk Assembly	4
D	BU07	Bunk Channel	8
E	BDL12	Bunk Down Leg	8
F	20676	Bunk Socket	8
H	W4	4000 lb. Winch	1
I	LS2005B/20886	41" Wheel/Shaft Adapter	1/1
J	20678	Bunk Socket Plate	8
K	20885F	Cradle Front	1
L	20839	Cradle Spreader	2
M	20862	Cradle Roller Kit	4
N	20837	Mainframe Spreader 120"	2
O	20837	Mainframe Spreader 120"	2
P	20832	Mainframe Post #1	1
Q	20885R	Cradle Rear	1
R	20833	Mainframe Post #4	1
S	20835	Leg Weld Assembly 36"	4

## PARTS LIST LSV40120BP

same as LSV30120BP with the addition of:

ref.	part no.	part name	qty.
T	20840	Diagonal Brace	4
U	20860	Diagonal Bracket	2
	20863	Bolt Package for Diagonal	1

## PARTS LIST LSV50120BP

same as LSV30120BP but replace:

ref.	part no.	part name	qty.
A	20901	Mainframe Post #3	1
B	20900	Mainframe Post #2	1
F	20902	Bunk Socket	8
H	W6	Winch	1
J	20904	Bunk Socket Plate	8
K	20898F	Front Cradle	1
Q	20898R	Rear Cradle	1
R	20900	Mainframe Post #4	1