



Ten/Two Year Limited Warranty

LSP, Inc. (Seller) warrants the aluminum structure on docks and lifts of its manufacture to be free from defects caused by material or workmanship for ten years from date of purchase. Seller will, at its option, repair or replace any such goods found on examination by Seller to be defective under normal use and service. Upon discovery of any such defect, Buyer must notify Seller in writing of defect and provide proof of purchase. Seller warrants all other materials including cast aluminum parts, mechanical components, hardware, canopy covers, cables, bunks, etc for two years. Components obtained from other manufacturers and used in Seller's products will be covered under the manufacturer's warranty and shall not be the responsibility of the Seller.

Seller's responsibility under this warranty shall be the repair or replacement of defective items. Seller is not liable for incidental or consequential damages of any kind.

Seller shall not be held responsible for repairs or modifications to its docks or lifts unless authorization has been obtained from Seller. This warranty does not cover damage caused by incorrect assembly or adjustments, overloading, improper use, neglected maintenance, alterations, or damage caused by accident, environmental factors (chemicals, tree sap, salt, etc), or acts of God (rainstorms, windstorms, tornadoes, etc).

Owner's Manual

LSP20H + LSP04H

Cantilever Pontoon Lift
3600 lbs. capacity

LSP20H

LS3120 mainframe bundle
LS3102H H-unit bundle
LS3103 accessory box

LSP04H

LS3104 extension bundle
LS3113 accessory box 4'

READ CAREFULLY - FAILURE TO FOLLOW INSTRUCTIONS AND SAFETY RULES MAY RESULT IN SERIOUS INJURY

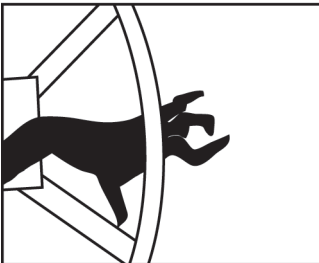

⚠ WARNING

DO NOT ATTEMPT TO STOP SPINNING WHEEL.
Serious personal injury could result.

Lift Wheel must be turned clockwise for lifting.
NEVER raise lift by turning wheel counterclockwise.
Doing so will result in an uncontrolled spin down, which could lead to cable failure and serious injury.

Z117

⚠ CAUTION

DO NOT CRANK PAST STOP POSITION.

When raising lift be aware that when moving components contact frame you have reached maximum height. Turning wheel past this point may cause personal injury and will cause damage to lift that is not covered by warranty.

Z119

⚠ WARNING

DO NOT OPERATE THIS HOIST WITHOUT FIRST STUDYING THE OWNER'S MANUAL.

1. Before operating this lift be sure to understand all operating procedures and safety precautions.
2. **NEVER** operate lift with people on board boat or near any part of lift.
3. **NEVER** work or play on, around or under lift.
4. **NEVER** exceed the rated capacity of lift. Doing so may cause lift to fail.
5. Before use visually inspect **SHEAVES** and **CABLE** for wear or fraying. Follow proper maintenance procedures.

Failure to follow these procedures could cause lift to fail and result in death or serious personal injury.

Z116

Manufacturers of Lakeshore Products

855 East Chicago Road, Quincy, MI 49082

www.lakeshoreproducts.com • tel: 517.639.3815 • fax: 517.639.4576

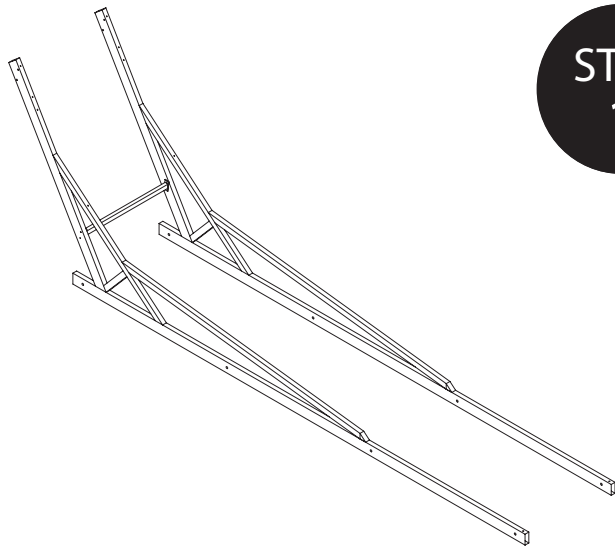

STEP 1

PARTS FOR THIS STEP	
MAINFRAME (T*)	2
LOWER SPREADER TUBE (P)	1
BOLT PACKAGE #1	1

* denotes letter on exploded view

With proper care and maintenance, this lift will provide you with years of trouble free service. Please follow these instructions carefully.

WARNING

Install all nuts and bolts loosely until the lift is fully assembled, then tighten all nuts and bolts properly.

Do not overtighten the nuts and bolts on your lift.

Doing so may cause the lift to fail. When tightening against a tube, tighten until the aluminum just dimples. If you crush the tube, it may crack and fail under normal use.

TOOLS NEEDED	
ADJUSTABLE WRENCHES	2
OR	
9/16 WRENCHES	2
3/4 WRENCHES	2

1.1 MAINFRAME setup

Stand the two **MAINFRAMES** upright. Place the smaller **LOWER SPREADER TUBE** between the frames at the bottom of the **MAINFRAME** upright tube, and attach using:

- 4 - 3/8" x 3" hex bolts
- 4 - 3/8" washers
- 4 - 3/8" nylon lock nuts

Place the washers under the heads of the bolts on the outside of the lift.

1.2 optional extension

Bolt the **MAINFRAME EXTENSIONS** on the **MAINFRAME**, placing the **MAINFRAME CONNECTORS** to the outside of the lift using:

- 4 - 3/8" x 6 1/2" hex bolts
- 8 - 3/8" washers
- 4 - 3/8" nylon lock nuts

Make sure the large hole in the **MAINFRAME EXTENSION** is away from the lift.

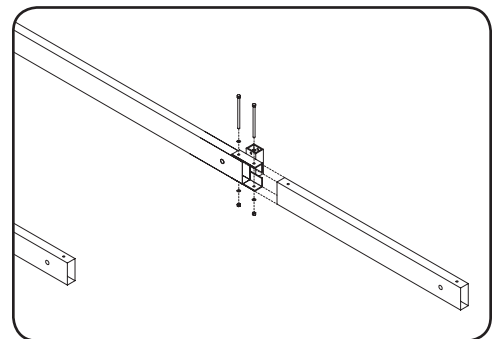

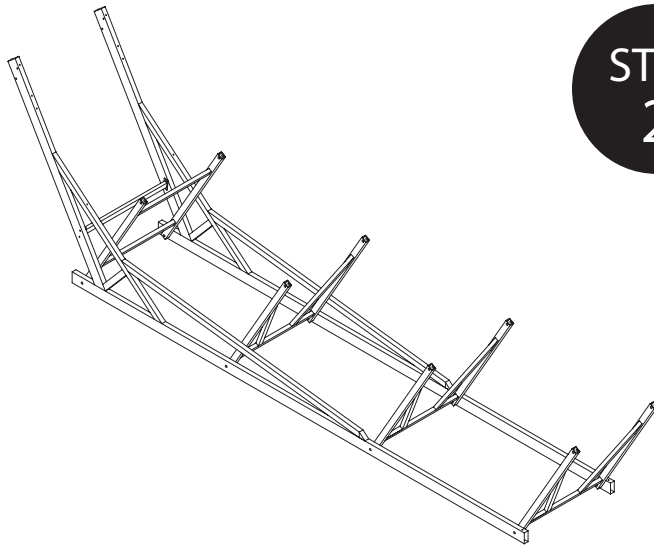

STEP 2

● PARTS FOR THIS STEP

FRONT H UNIT (R)	1
REAR V-UNIT (S)	2/3/4
BOLT PACKAGE #2	1

2.1 install H UNITS

Place the **H-UNIT** between the **MAINFRAMES** at the front of the lift with the pulley holes 7" down from the top. Attach using:

- 1 - 1/2" x 5 1/2" hex bolts
- 3 - 1/2" flat washers
- 1 - 1/2" nylon lock nuts

place one washer under the bolt head, one under the nut, and one between the tubes.

Attach the **V-UNITS** in the same manner.

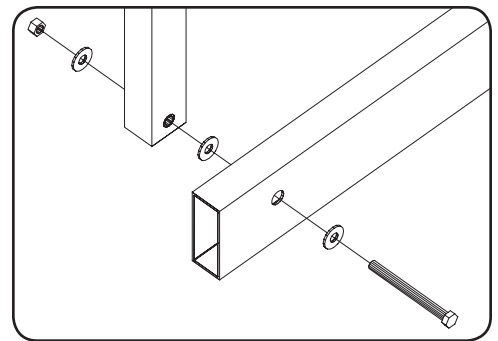

2.2 optional extension

Repeat as above for extra **V-UNITS**.

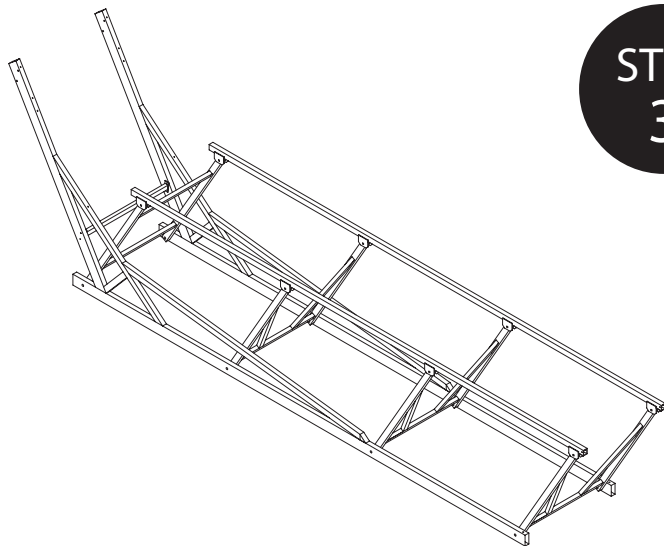

STEP 3

PARTS FOR THIS STEP	
CRADLE (D)	2
BOLT PACKAGE #3	1

3.1 install CRADLES

Lay the **CRADLE** tubes in position on top of the **H-UNIT** and **V-UNITS** with the **CRADLE ROLLERS** located at the rear of the lift. Turn the drilled tabs to the bottom of the **CRADLE** tubes and place over the tops of the leg **UNITS**, attach using:

- 1 - 1/2" x 3 1/2" carriage bolts
- 1 - 1/2" flat washers
- 1 - 1/2" nylon lock nuts

Be sure to place the nuts on the inside of the lift with the washers underneath them. Repeat for each set of tabs.

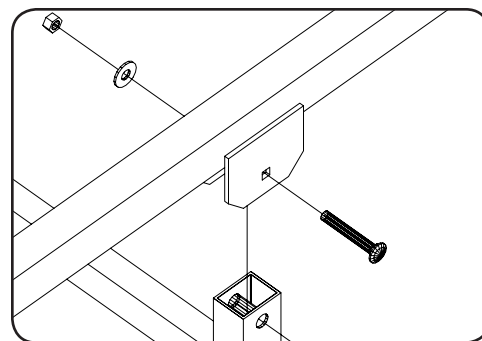

3.2 optional extension

Attach the **CRADLE EXTENSIONS** by first removing the **CRADLE ROLLERS** and reinstalling them on the **EXTENSION**. Then place the **CRADLE CONNECTORS** on the bottom of the **CRADLES** and bolt in place using:

- 4 - 3/8" x 3" hex bolts
- 8 - 3/8" washers
- 4 - 3/8" nylon lock nuts

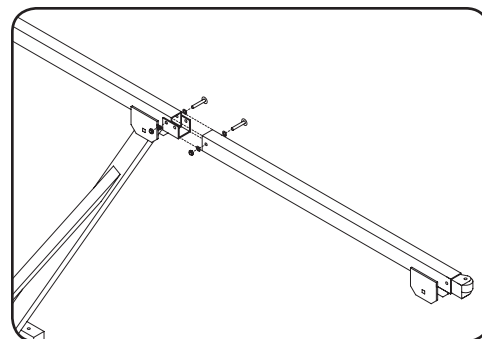

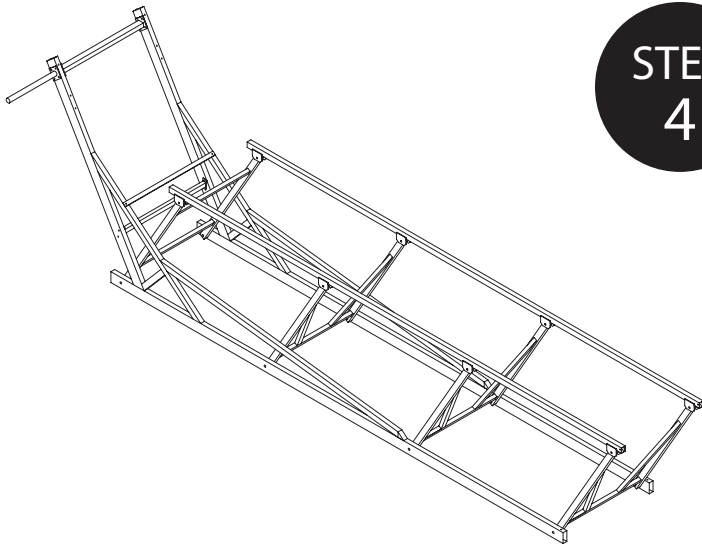

STEP 4

PARTS FOR THIS STEP	
UPPER SPREADER TUBE (G)	1
STOP BAR (H)	1
CABLE	1
WHEEL SUPPORT TUBE (L)	1
BOLT PACKAGE #4	1

4.1 install UPPER SPREADER TUBE and STOP BAR

Attach the **UPPER SPREADER TUBE** between the **MAINFRAMES** using bolt package #4:

- 1 - 1/2" x 3" hex bolts
- 1 - 1/2" flat washer
- 1 - 1/2" nylon lock nuts

bolt through the **MAINFRAME** and into the bottom hole of the plate.

Lay the **CABLE** out straight and bolt through the upper hole of the **SPREADER TUBE** using:

- 1 - 1/2" x 3 1/2" hex bolts
- 1 - 1/2" flat washer

Install the looped end of the **CABLE** over the bolt using:

- 1 - 3/4" flat washer
- 1 - 1/2" flat washer
- 1 - 1/2" nylon lock nuts

be sure to tighten so that the **CABLE** will not come loose.

Install the **STOP BAR** on the mainframe brace using:

- 2 - 5/16" x 3 1/2" hex bolts
- 2 - 5/16" nylon lock nuts

be sure that the STOP label is visible.

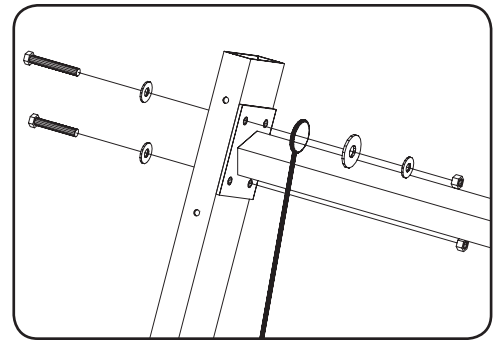

4.2 WHEEL SUPPORT TUBE

Attach the **WHEEL SUPPORT TUBE** and the other end of the **UPPER SPREADER TUBE** to the mainframe with bolt package #5:

- 2 - 1/2" x 3 1/2" hex bolts
- 2 - 1/2" nylon lock nuts

the bolt heads should be on the outside of the lift.

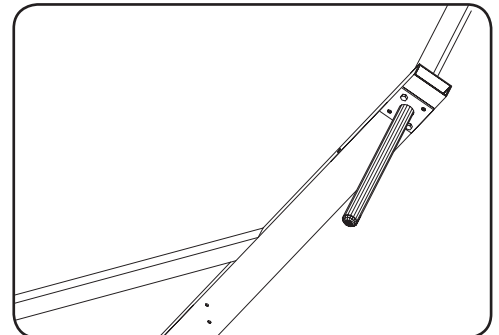

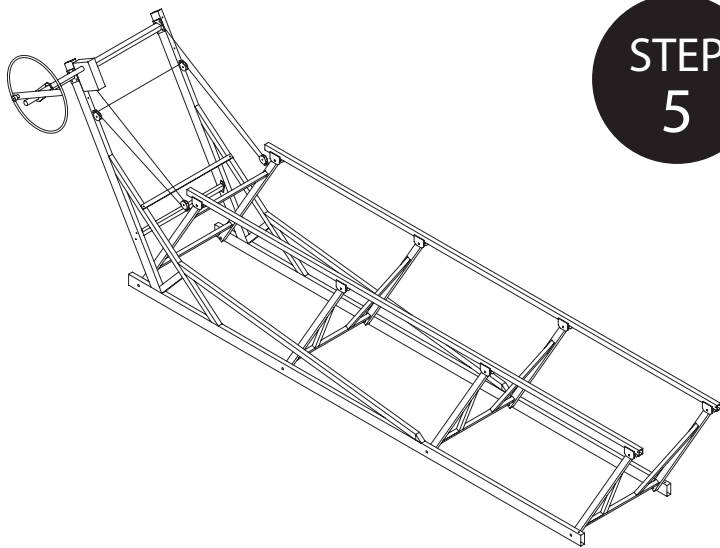

STEP 5

PARTS FOR THIS STEP	
WINCH (I)	1
WHEEL EXTENSION TUBE (K)	1
WHEEL SUPPORT ASSEMBLY (M)	1
32" WHEEL (N)	1
3" PULLEY KIT (Q)	2
6" PULLEY KIT (O)	2
CAP 2" X 2.5" (E)	2
CAP 2" X 5" (F)	2
BOLT PACKAGE #5	1/1

5.1 mounting the WINCH

In attaching the **WINCH** to the **MAINFRAME**, place the **WINCH** shaft towards the outside of the lift and bolt using:

- 2 - 3/8" x 6 1/2" hex bolts
- 2 - 3/8" flat washers
- 2 - 3/8" nylon lock nut

with the washers and nuts inside the **WINCH**.

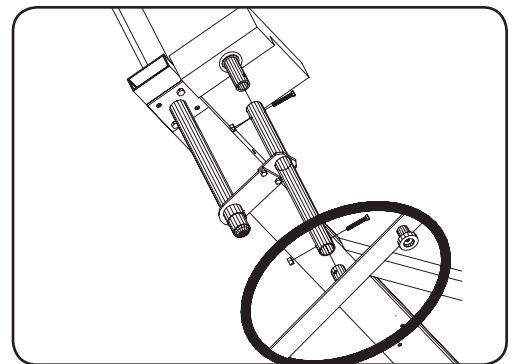

5.2 WHEEL

Bolt the **WHEEL EXTENSION TUBE** to the **WINCH** shaft. Slide the white portion of the **WHEEL SUPPORT ASSEMBLY** over the **WHEEL EXTENSION TUBE**. Turn the bracket until you can slide it just past the end of the **WHEEL SUPPORT ASSEMBLY**. Adjust so that the tubes are parallel and tighten the bolt that holds the bracket in position. Bolt the **WHEEL** to the **WHEEL EXTENSION TUBE** and tighten to secure.

NOTE

The wheel needs to thread on and off the shaft to activate the brake. This shaft should be greased yearly to ensure proper operation.

Extreme care should be taken not to cross thread and damage the threads on the wheel hub. This will void your warranty.

5.3 install PULLEYS

Install the 3" **PULLEYS** to the front of the **H-UNIT** and the 6" **PULLEYS** to the **MAINFRAME** upright tubes in the holes that are approximately 12" below the **UPPER SPREADER TUBE**. Secure using:

- 4 - 1/2" flat washers

5.4 string CABLE

Take the loose end of the **CABLE** and run it over the pulley on the **H-UNIT** closest to where the **CABLE** is attached. String it back through the mainframe **PULLEY** on the same side of the lift and then over through the mainframe **PULLEY** on the opposite side. String under the remaining H-unit **PULLEY**. Locate the cable hole in the winch drum inside the bottom of the **WINCH**. The drum may have to be turned so the slot and the clamp screws are accessible. Loosen the clamp screw and thread the straight end of the cable through the hole until approximately 1" is sticking out. Tighten the clamp screws down with a 5/32 allen wrench until the **CABLE** is held securely. This is done through the hole in the side of the winch next to the shaft.

Take up the slack in the **CABLE** by turning the **WHEEL** clockwise. Make sure the **CABLE** winds evenly. Double check that the lift is working properly as it is raised and that all pulleys are turning freely. After the first few times the **WINCH** is used check the clamp screws for tightness and tighten if required.

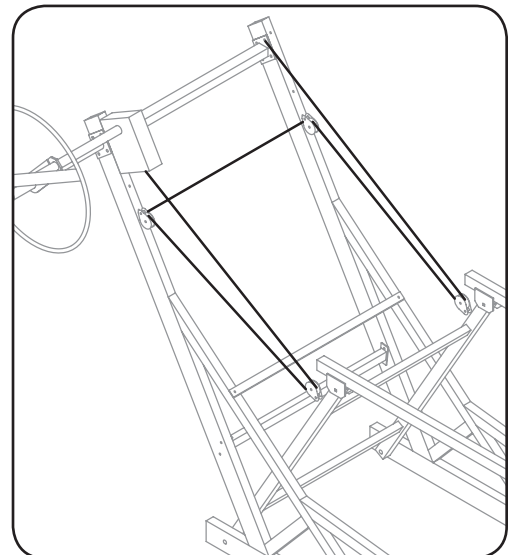

5.5 final adjustments

Now tighten all nuts and bolts, except the ones that must be free to allow the **H-UNITS** to pivot. Install the 4 **CAPS**, 2 at the top of the **MAINFRAME** and 2 on the **CRADLES**. Move your lift into the water and position it so that the lift is level. If your lake bottom is uneven, we offer Leg Kits that enable you to level your pontoon lift. The installation is now complete.

NOTE

Never over crank the winch. Once the lift has reached its highest point, further cranking will damage the lift.

hints

- A. Deep water? Extension legs are available in 1', 2', 3' and 4' length.
Call your Dealer for pricing.
- B. The front Cable will last much longer if you grease the first 5' to 8' that goes into the winch.
- C. The winch and brake mechanism will work better if the wheel shaft is greased yearly. This task has been simplified by the addition of a grease fitting on the wheel shaft right behind the red wheel.
- D. Do not over crank your lift. Be sure to notice the maximum height that your lift will rise to and **STOP** when you reach that height.
Failure to do so will damage your lift.

important

- A. Grease the winch shaft annually. The red wheel must be able to thread and unthread easily in order for the braking mechanism to work properly.
- B. Your LSP lift will only protect your watercraft if the craft is lifted well above the level of the water. In larger lakes or during storms, large waves may lift the craft from the lift or tip the lift over, causing damage both to the craft and the lift. You must take precautions to protect your craft and lift from these conditions. If your craft suffers damage from high waves, LSP, Inc. will not accept responsibility for such damage.
- C. Inspect your lift often for signs of wear or improper operation. Be aware of normal cranking force. Any increase in cranking force is a sign that something is wrong. **DO NOT USE** the lift if any parts are worn or damaged, replace immediately.
- D. Pay attention to the condition of your cable. A frayed or rusted cable can lead to failure of the lift. Replace it immediately. Greasing the cable, especially where it enters the winch, can extend its life.
- E. A second caution decal is provided in the accessories box. If after assembly the decal is not easily seen then install the extra decal so that anyone using the lift can read it. **NEVER** let anyone operate the lift unless they are familiar with all safety rules.
- F. **NEVER** let anyone play on, around, or under the lift.

BP2124PL BOLT PACKAGE

20711	STEP 1	
X412	3/8" x 3" hex bolt	4
Z451	3/8" hex lock nut	4
X452	3/8" flat washer	4
20716	STEP 2	
X514C	1/2" x 3 1/2" carriage bolt	8
Z551	1/2" hex lock nut	8
X552	1/2" flat washer	8
20713	STEP 3	
X314	5/16" x 3 1/2" hex bolt	2
Z351	5/16" hex lock nut	2
X522	1/2" x 5 1/2" hex bolt	8
Z551	1/2" hex lock nut	8
X552	1/2" flat washer	24
20918	STEP 4	
X512	1/2" x 3" hex bolt	1
X514	1/2" x 3 1/2" hex bolt	3
Z551	1/2" hex lock nut	4
X552	1/2" flat washer	3
20719	STEP 5	
X426	3/8" x 6 1/2" hex bolt	2
Z451	3/8" hex lock nut	2
X452	3/8" flat washer	2
X552	1/2" flat washer	4

BP04PL BOLT PACKAGE

CP	38" x 2.5" clevis pin	2
HPC	hairpin cotter	2
21081	STEP 1	
X426	3/8" x 6 1/2" hex bolt SS	4
X452	3/8" flat washer SS	8
Z451	3/8" hex lock nut	4
21082	STEP 2	
X522	1/2" x 5 1/2" hex bolt SS	2
X552	1/2" flat washer SS	6
Z551	1/2" hex lock nut	2
21083	STEP 3	
X412	3/8" x 3" hex bolt SS	4
X452	3/8" flat washer SS	8
Z451	3/8" hex lock nut	4
X514C	1/2" x 3 1/2" carriage bolt SS	2
X552	1/2" flat washer SS	2
Z551	1/2" hex lock nut	2

LSP20H + LSPO4H Cantilever Pontoon Lift, 3600 lbs. Capacity, 47.75" Width, 60" Lift Height

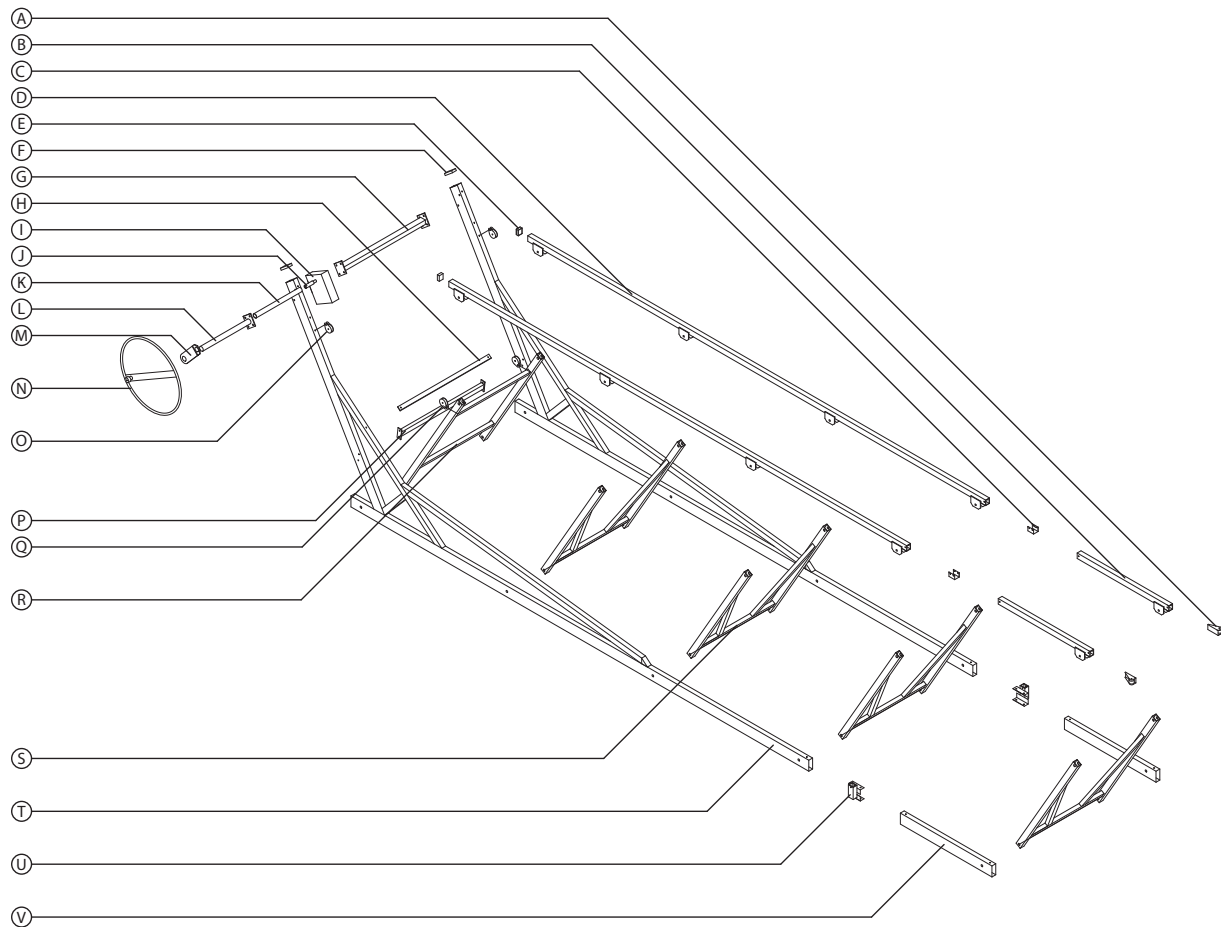

PARTS LIST

REF.	PART NO.	PART NAME	QTY.
A	PRK	pontoon cradle roller kit	2
B	21080	cradle extension 4'	2*
C	21079	cradle connector	2*
D	21078	cradle weld assy 20'	2
E	CAPS2025	2" x 2 1/2" cap	2
F	CAPS2050	2" x 5" cap	2
G	20579	upper spreader tube	1
H	20876	stop bar	1
I	W5	3500 lb. winch	1
J	WSL	winch shaft adapter	1
K	20021	wheel extension tube	1
L	20111	wheel support tube	1
M	20888	wheel support assembly	1
N	LS3004	32" pontoon wheel	1
O	PUL6	6" pulley kit	2
P	20581	lower spreader tube	1
Q	PUL3	3" pulley kit	2
R	20583	front H-unit	1
S	20590	rear V-unit	3+1*
T	21075	mainframe 20'	2
U	21076	mainframe connector	2*
V	21077	mainframe extension 4'	2*
	20640	cable 1/4" x 37' (not shown)	1

* included in LSP04H

LS3103 ACCESSORY PACKAGE

21079	pontoon cradle connector	2
BP2124PL	bolt package with steps 1-5	1
20021	wheel extension tube 24"	1
20888	wheel support bracket	1
W5	aluminum winch	1
20640	cable with loop in one end	1
PUL3	3" pulley kit	2
PUL6	6" pulley kit	2
CAPS2025	2" x 2.5" cap	2
CAPS2050	2" x 5" cap	2
Z116	caution decal	1

LS3113 ACCESSORY PACKAGE

BP04PL	bolt package LSP04H	1
21076	pontoon MF connector	2
21079	pontoon cradle connector	2