



# Owner's Manual

## LSV1364

1300 lb, 64" Beam Vertical Lift

READ CAREFULLY - FAILURE TO FOLLOW INSTRUCTIONS AND SAFETY RULES MAY RESULT IN SERIOUS INJURY



### ▲ WARNING

**DO NOT ATTEMPT TO STOP SPINNING WHEEL.**  
Serious personal injury could result.

Lift Wheel must be turned clockwise for lifting.  
**NEVER** raise lift by turning wheel counterclockwise.  
Doing so will result in an uncontrolled spin down,  
which could lead to cable failure and serious injury.

Z117

### ▲ CAUTION

**DO NOT CRANK PAST STOP POSITION.**

When raising lift be aware that when moving components  
contact frame you have reached maximum height.  
Turning wheel past this point may cause personal injury  
and will cause damage to lift that is not covered by warranty.

Z119

## ▲ WARNING

**DO NOT OPERATE THIS HOIST WITHOUT FIRST STUDYING THE OWNER'S MANUAL.**

1. Before operating this lift be sure to understand all operating procedures and safety precautions.
2. **NEVER** operate lift with people on board boat or near any part of lift.
3. **NEVER** work or play on, around or under lift.
4. **NEVER** exceed the rated capacity of lift. Doing so may cause lift to fail.
5. Before use visually inspect **SHEAVES** and **CABLE** for wear or fraying. Follow proper maintenance procedures.

**Failure to follow these procedures could cause lift to fail and result in death or serious personal injury.**

Z116

Manufacturers of Lakeshore Products

855 East Chicago Road, Quincy, MI 49082

www.lakeshoreproducts.com • tel: 517.639.3815 • fax: 517.639.4576

# LSV1364 1300 lb, 64" Beam Vertical Lift

With proper care and maintenance, this lift will provide you with years of trouble free service. Please follow these instructions carefully.

## NOTE

Install all nuts and bolts loosely until the lift is fully assembled, then tighten all nuts and bolts properly.

Do not overtighten the nuts and bolts on your lift.

Doing so may cause the lift to fail. When tightening against a tube, tighten until the aluminum just dimples. If you crush the tube, it may crack and fail under normal use.

## tools needed

adjustable wrenches	2
or	
1/2" wrenches	2
9/16" wrenches	2
7/16" wrench [for winch]	1

## 1. mainframe setup

mainframes [right and left] w/ legs attached	2
---	---

Setup the Mainframes.

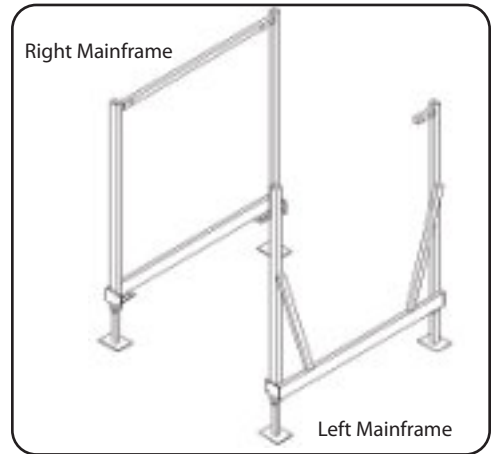

## 2. mainframe spreader

mainframe spreader tubes	2
bolt package step 2	1

Bolt the Mainframe Spreader tube between the mainframes using:

- 4 - 3/8" x 5 1/2" hex bolts
- 8 - 3/8" flat washers
- 4 - 3/8" nylon lock nuts

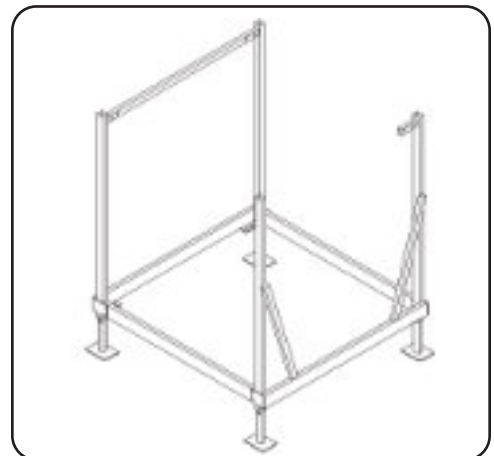

## 3. install winch

winch 1500#	1
red wheel 25"	1
bolt package step 3	1

Install the winch on the tallest post using:

- 2 - 3/8" x 3 1/2" hex bolts
- 2 - 3/8" flat washers
- 2 - 3/8" nylon lock nut
- 2 - large aluminum washers

The large washers go on the outside of the post with the small washer inside the winch.

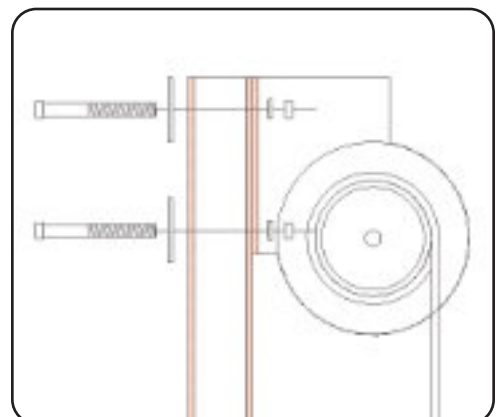

## 4. install wheel

CAREFULLY thread the 25" red Wheel onto the winch shaft. The Wheel should be able to thread on and off the shaft easily. This is the action that activates the brake mechanism.

Turn the Wheel clockwise and you should here a clicking sound, this means the brake is working. This raises the lift and keeps it raised wherever you stop.

Turn the Wheel counter clockwise and the brake is released allowing the lift to lower.

To keep the Wheel from coming off the shaft fasten using:

- 1 - winch spring
- 1 - 1/2" jam lock nut

Tighten the nut just until 1 or 2 threads of the shaft are visible while preventing the winch shaft from turning.

### NOTE

The wheel needs to thread on and off the shaft to activate the brake. This shaft should be greased yearly to ensure proper operation.

Extreme care should be taken not to cross thread and damage the threads on the wheel hub. This will void your warranty.

## 5. assemble cradle

front cradle	1
rear cradle	1
leveling spreader	1
lift spreader	1
bolt package step 5	1

Assemble cradle unit outside of mainframe using:

- 8 - 5/16" x 2 1/2" hex bolts
- 16 - 5/16" flat washers
- 8 - 5/16" nylon hex nuts

- Loop ends of cables should face up
- Cable ends with barrels should face down
- Bolt heads face outside, nuts face inside

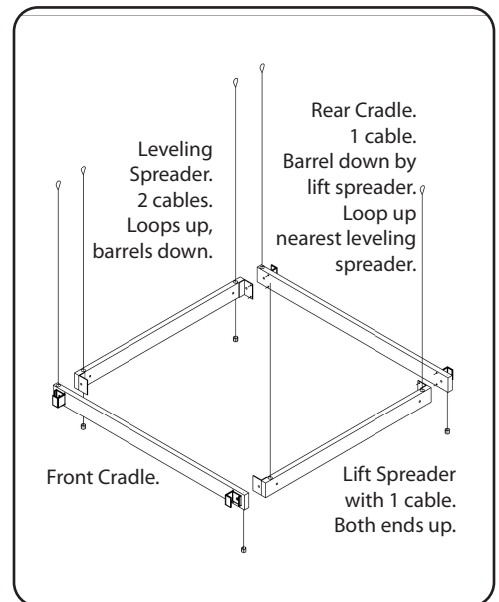

## 6. lift cradle into mainframe

Position assembled cradle unit so that the Lift Spreader is next to the Left Mainframe (winch side), and the free end of the cable is directly under the winch.

## 7. string cables

**bolt pkg step 7** **1**

Attach the loop end of the Lift Spreader cable to the post opposite the winch using:

- 1 - 3/8" x 2" hex bolt
- 1 - 3/8" nylon lock nut

Take the free end of the cable and secure it to the winch following the instructions included with the winch.

Next attach each barrel end into the corresponding keyhole in the Main-frame base plates. Slide each into the narrow slot and insert

- 4 - 5/8" clevis pins
- 4 - hairpin cotters

to lock the cable in position. Because these are two keyholes in each base-plate, be sure to use the keyholes that will best align with the cable ends.

Repeat 3 times.

Now attach all the loop ends to the bar running across the top of the Right Mainframe (opposite the winch side), using:

- 4 - 3/8" x 2" hex bolts
- 4 - 3/8" nylon lock nuts

Use the lower holes. The upper holes may be used if there is too much slack in cable.

<b>accessory package 1364</b>	<b>1</b>
<b>bunk adjustment channels</b>	<b>4</b>
<b>channel backer plates</b>	<b>4</b>
<b>1500# DL winch and booklet</b>	<b>1</b>
<b>2" x 2.5" grey plastisol caps</b>	<b>4</b>

## 8. bunks

**carpeted bunks** **2**  
**bunk adjustment channels** **4**  
**bunk backer plates** **4**  
**bolt package step 8** **1**

Attach the carpeted Bunks to the Front and Rear Cradles using:

- 4 - 5/16" x 1" hex bolts
- 8 - 5/16" x 2-1/2" hex bolts
- 12 - 5/16" nylon lock nuts

The 1" bolts attach the U shaped Bunk Adjustment Channel to the angle attached to the Bunk. These go to the inside of the lift. The 2 1/2" bolts attach the Backer Plates to the Bunk Adjustment Channels on either side of the Cradles.

For most uses Bunks should be placed approximately 18" apart.

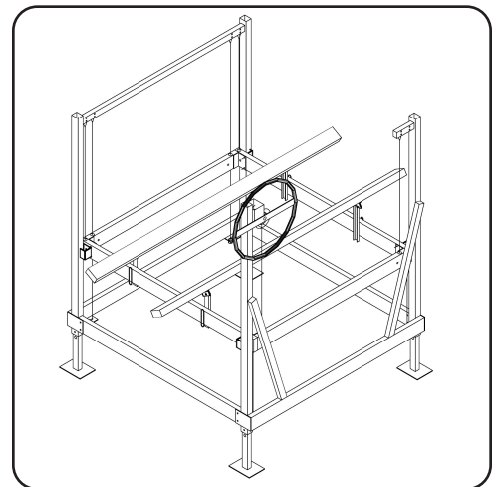

## 9. final adjustments

**grey cap 2" x 2.5"** **4**

Now tighten all nuts and bolts.

Install the 4 grey plastisol caps on top of the Mainframe posts .

Move your lift into the water and adjust its legs so that the lift is level. The legs can be removed to lower the lift if the water is very shallow.

Adjust the bunk height just high enough so your craft's bottom will not hit the cradle.

The installation is now complete.

### NOTE

**Never over crank the winch. Once the lift has reached its highest point, further cranking will damage the lift.**

## hints

- A. Once you are happy with your bunk adjustment, tighten the bolts that hold the bunks to the bunk channels. Movement of the bunks causes wear.
- B. Deep V hulls may be accommodated by moving the front of the bunks closer together and leaving the back farther apart to provide stability.
- C. In deep water ? If you have a deep lake and are in need of longer legs, LSP, Inc. offers 4 foot long legs for your PWC Lift. Ask your dealer for details or call us at 517.639.3815.
- D. Greasing the cable where it wraps around the winch drum will increase cable life.

## important

- A. Grease the winch shaft annually. The red wheel must be able to thread and unthread easily in order for the braking mechanism to work properly.
- B. Your LSP PWC Lift will only protect your personal watercraft if the craft is lifted well above the level of the water. In larger lakes or during storms, large waves may lift the craft from the lift or tip the lift over, causing damage both to the craft and the lift. You must take precautions to protect your craft and lift from these conditions. If your craft suffers damage from high waves, LSP, Inc. will not accept responsibility for such damage.
- C. Inspect your lift often for signs of wear or improper operation. Be aware of normal cranking force. Any increase in cranking force is a sign that something is wrong. DO NOT USE the lift if any parts are worn or damaged, replace immediately.
- D. Pay attention to the condition of your cable. A frayed or rusted cable can lead to failure of the lift. Replace it immediately. Greasing the cable, where it enters the winch, can extend its life.
- E. A second caution decal is provided in the accessories box. If after assembly the decal is not easily seen then install the extra decal so that anyone using the lift can read it. NEVER let anyone operate the lift unless they are familiar with all safety rules.
- F. NEVER let anyone play on, around, or under the lift.

## 25/2 Year Limited Warranty

*Effective for all products purchased after January 1, 2026.*

**Twenty Five Years on Aluminum Structure** We (LSP, LLC) warrant the aluminum structure on the docks and lifts that we manufacture to be free from defects caused by material or workmanship for twenty five years from the date of purchase.

**Two Years on Components** We warrant all other materials including cast aluminum parts, mechanical components, hardware, canopy covers, cables, bunks, etc. for two years.

**Other Manufacturers' Parts** Any components obtained from other manufacturers for use in our products are covered under the original manufacturer's warranty by the original manufacturer. We will support the resolution of any failures of these parts, but do not warrant them ourselves.

**Defective Part?** Should you discover a defect in one of our products, contact the dealer you purchased the product from. If you need to find a local dealer, use the Dealer Locator on our website or contact us directly at [lakeshoreproducts.com](http://lakeshoreproducts.com).

**What will we do?** Working through your local dealer, we will repair or replace any parts or components that we determine to be defective under normal use and service. The dealer will perform the exchange of parts and any labor that may be necessary.

### Legal Stuff

Our responsibility under this warranty is limited to the repair or replacement of defective items and does not include incidental or consequential damages of any kind. We are not responsible for failures or damage due to repairs or modifications to our products that we have not previously approved; incorrect assembly or adjustment, overloading, improper use, neglected maintenance; or resulting from an accident, environmental factors (chemicals, tree sap, salt, etc.), extreme weather, or natural disasters (rainstorms, windstorms, tornadoes, etc.).

# LSV1364 1300 lb, 64" Beam, 61" Lift Height.

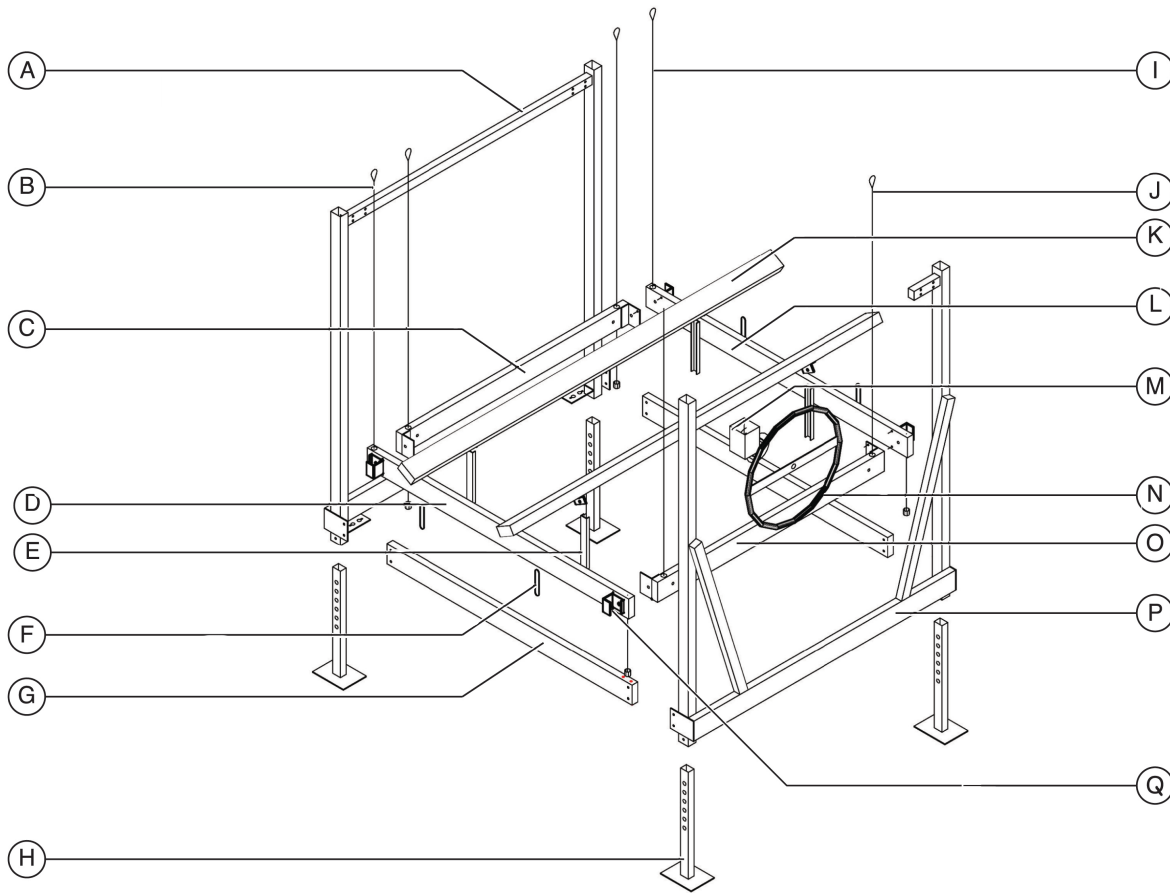

## PARTS LIST

ref.	part no.	part name	qty.
A	20953	right mainframe	1
B	20974	transfer cable	2
C	20956B	leveling spreader	1
D	20955	front cradle	1
E	20501	bunk adjustment channel	4
F	20502	channel backer plate	4
G	20954	mainframe spreader	2
H	JLU/CP/HPC	leg/clevis pin/hairpin cotter	4
I	20975	leveling cable	2
J	20973	lift cable	1
K	20957	bunk assembly	2
L	20955	rear cradle	1
M	JLDWINCHD	1500# winch	1
N	LS1102	25" wheel	1
O	20956	lift spreader	1
P	20952	left mainframe (winch)	1
Q	21098	cradle bracket	4

## LSV1364 BOLT PACKAGE

part no.	description	qty.
20970	STEP 2	
X422	3/8" x 5 1/2" hex bolt	8
X452	3/8" flat washer	16
Z451	3/8" nylon lock nut	8
20971	STEP 3	
X414	3/8" x 3 1/2" hex bolt	2
Z451	3/8" nylon lock nut	2
X452	3/8" flat washer	4
20498	winch hardware	1
20981	washer large aluminum	2
20972	STEP 5	
X310	5/16" x 2 1/2" hex bolt	8
X352	5/16" flat washer	16
Z351	5/16" nylon lock nut	8
20980	STEP 7	
X408	3/8" x 2" hex bolt	5
Z451	3/8" nylon lock nut	5
CP9	5/8" clevis pin	4
HPC	hairpin cotter	4
20637	STEP 8	
X304	5/16" x 1" hex bolt	4
X310	5/16" x 2 1/2" hex bolt	8
Z351	5/16" nylon lock nut	12