

LSV36108A 3600# Vertical Lift

Instruction Manual

**Read carefully.
Failure to follow the instructions
and safety rules could result in
severe injury or death !**

LSV36108A

LS5001A
LS5002A
LS3003
LS4004
LS5005A
LS2005

LSV36108A Parts List

ref. no.	part No.	part name	qty
1	KNOB	Spinner Knob	1
2	Y756	5/8 Jam Nut	1
3	41W	41" Wheel	1
4	WC1	#1 Winch Cover	1
5	WLS	Winch Locking Sprocket	1
6	WINCHBP1	Winch Brake Pad	1
7	20039	Winch Wedge	1
8	W1	Large Winch (#1)	1
9	W952	Bronze Thrust Washer	1
10	WSC1	Large Winch Stop Cover	1
11	20147	Large Winch Spring	1
12	DEM3535	3-1/2 x 3-1/2 Plastisol Cap	4
13	20322	mainframe post #1	1
14	20741	front cable 288"	1
15	20765	mainframe post #2	1
16	DEM12	1-1/2 x 2 Plastisol Cap	3
17	20065	Cradle Roller	8
18	20339	Front Cradle Assembly	1
19	BUNK4000	Carpeted Wood Bunk Assy	2
20	20190	Mainframe Backer Plate Short	6
20	20673	Mainframe Backer Plate Long	2
21	20345	Cradle Spreader Tube - Left	1
22	20765	mainframe post #4	1
23	20119	Bunk Post Socket Assy	4
24	20339	Rear Cradle Assembly	1
25	20344	Cradle Spreader Tube - Right	1
26	20330	Mf 120" Spreader Tube	2
27	VAB2	angle brace 71.5"	4
28	20327	leg 36"	4
29	20767	side cable 195.5"	2
30	20766	mainframe post #3	1
31	VAB1	angle brace 46.625"	4
32	20331	Mf 108" Spreader Tube	2
33	20531	double pulley system	2
34	20532	single pulley system	6
35	20554	Roller Bearing Assembly	6
36	20743	rear cable 195.5"	2

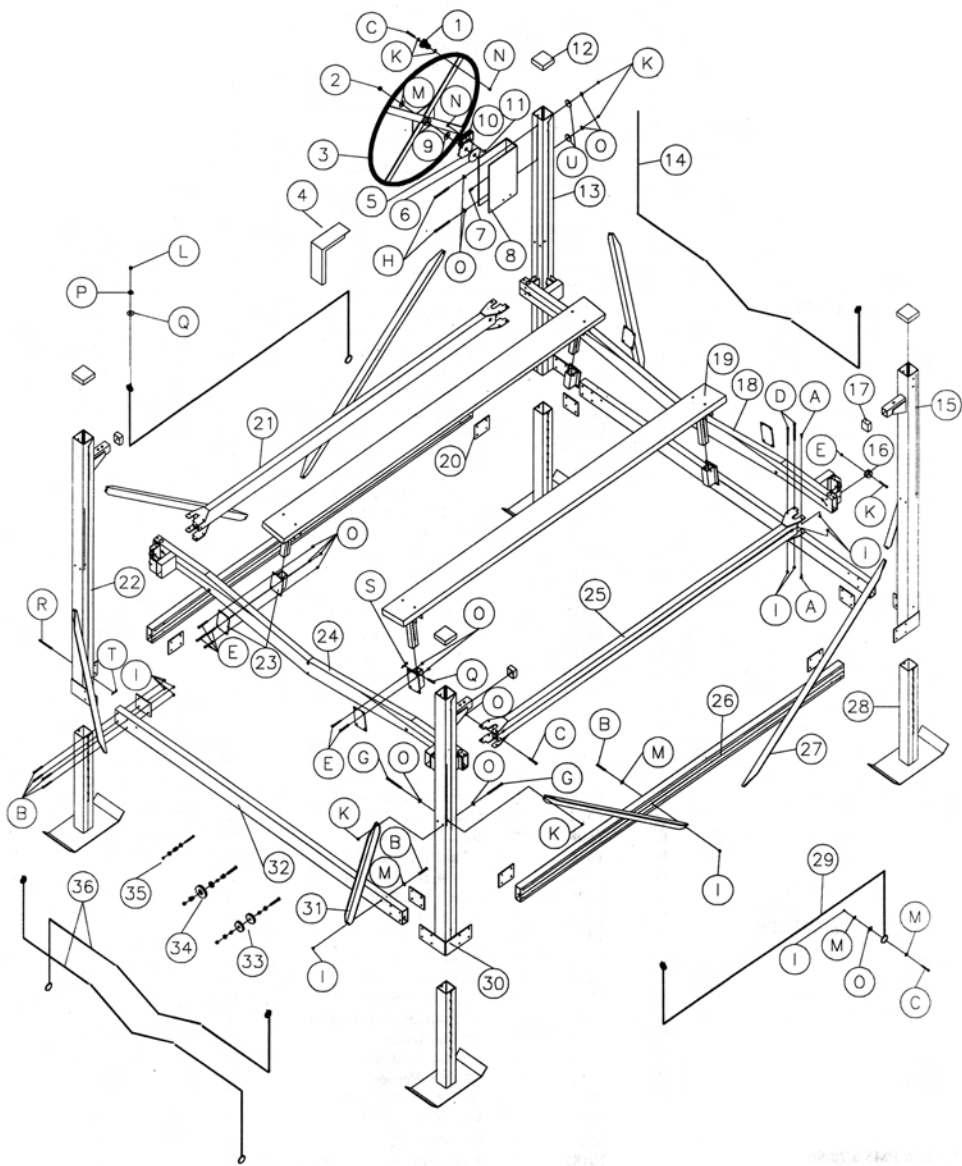

3600# Vertical Lift

Thank you for purchasing a Lakeshore Vertical Lift. With proper care and maintenance, this lift will provide you with years of trouble free service. Please follow these instructions carefully.

Each bolt pack is labeled to correspond to the steps listed in this manual. We have made assembly of your new lift as simple as possible. Below is a list of the components included in your accessory package.

WARNING

Do not over tighten the nuts and bolts on your lift. Doing so may cause the lift to fail. When tightening against a tube, tighten until the aluminum just dimples. Lock nuts should be tightened until at least one thread of the bolt is showing through the nut. If you crush the tube, it may crack and fail under normal use.

tools needed

1/2 wrenches	2
9/16 wrenches	2
15/16 or adjustable wrench	1
tape measure	1
step ladder	1
grease	

accessory package

bolt package with steps 1-8	1
aluminum winch	1
bunk socket	4
bunk socket plates 4" x 6.5"	4
cradle rollers	8
short mainframe plates	6
long mainframe plates	2
3.5" x 3.5" red plastisol caps	4
1.5" x 4.5" red plastisol caps	3

1. legs

Insert the legs into the posts using:

- 4 - 3/8 x 4 clevis pins
- 4 - hairpin cotters

mainframe posts	4
legs	4
bolt package step 1	1

2. mainframe spreaders and cables

Bolt the mainframe spreader tubes between the posts using:

- 14 - 5/16 x 2-1/2 hex bolts
- 14 - 5/16 nylon lock nuts

mainframe spreaders	4
short mf plates	6
long mf plates	2
bolt package step 2	1

Insert bolts in cable attachment holes using:

- 2 - 5/16 x 3 hex bolts
- 2 - 5/16 flat washers
- 2 - 1/2 flat washers
- 2 - 5/16 nylon lock nuts

the cables will be attached here in step 7.

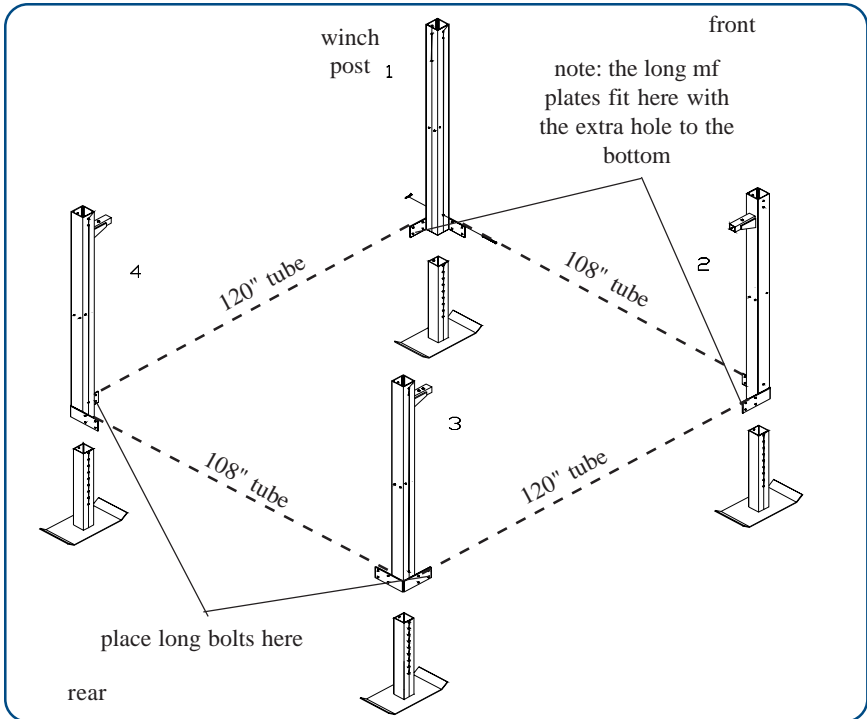

3. angle braces

Attach the long angle braces to the sides of the lift and the short angle braces to the front and rear of the lift. At the tops of the braces, use:

- 8 - 3/8 x 4-1/2 hex bolts
- 8 - 3/8 flat washers
- 8 - 3/8 nylon lock nuts

At the bottoms of the braces, use:

- 8 - 5/16 x 2-1/2 hex bolts
- 8 - 5/16 flat washers
- 8 - 5/16 nylon lock nuts

Square the mainframe by measuring its diagonals. The diagonals must be equal. If they are not, adjust the mainframe until they are. Once this is accomplished, tighten all of the bolts except the 5/16 x 3 hex bolts. The cables in the rear cradle will attach to these.

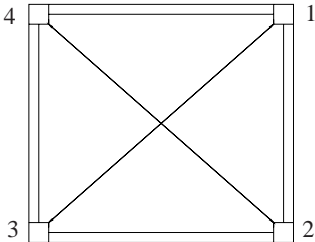

- | | |
|----------------------------|----------|
| long angle brace | 4 |
| short angle brace | 4 |
| bolt package step 3 | 1 |

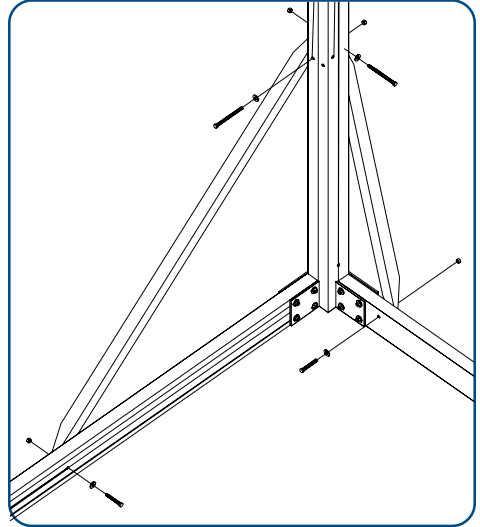

4. cradle

Bolt the cradle spreaders onto the cradles using:

- 12 - 5/16 x 5-1/2 hex bolts
- 12 - 5/16 nylon lock nuts

Square the cradle and tighten all of the bolts.

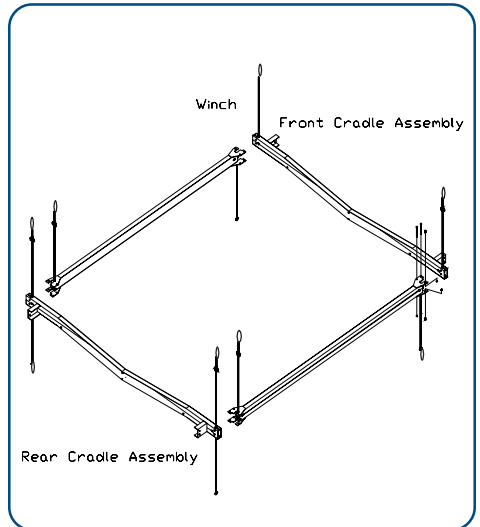

- | | |
|-----------------------------------|----------|
| cradle spreaders | 2 |
| cradles - front & rear | 2 |
| bolt package step 4 | 1 |

5. rollers

Install cradle rollers using:

- 8 - 3/8 x 2 hex bolts
- 8 - 3/8 nylon lock nuts

**cradle rollers
bolt package step 5**

**8
1**

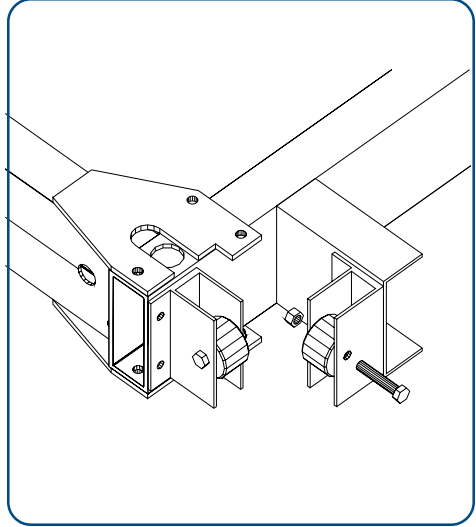

6. winch

With a ladder, attach the winch using:

- 2 - 3/8 x 5 hex bolts
- 2 - 3/8 flat washers
- 2 - large aluminum washers
- 2 - 3/8 nylon lock nuts

One washer belongs under the head of each bolt.

The aluminum washer and the other washer go under the nut on the outside of the lift.

Make certain that the large drum inside the winch is on the bottom of the winch.

Tighten these bolts.

Carefully thread the wheel onto the winch shaft and then place the washer and jam nut onto the winch shaft. Tighten the jam nut until the threads of the shaft just show through. Further tightening may keep the winch from working properly.

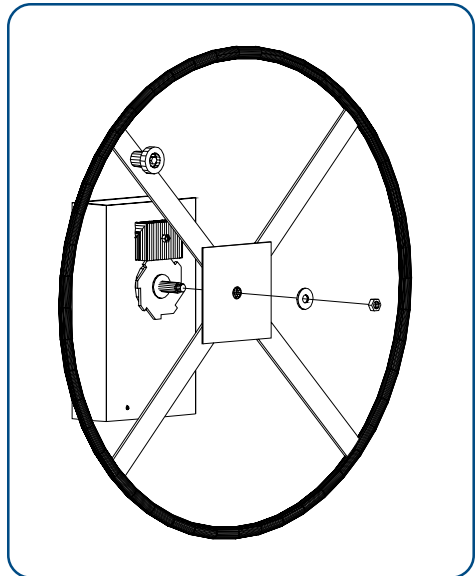

**winch
41" red wheel
bolt package step 6**

**1
1
1**

7. cable attachment

Find the loops that hang out the front end of the cradle. These attach to the two bolts that you left loose on the front of the mainframe. Put the cable loop against the backer plate, followed by the 1/2 washer, the 3/8 washer, and then the 3/8 lock nut.

- 2 - 3/8 x 3 hex bolts
- 4 - 3/8 flat washers
- 2 - 1/2 flat washers
- 2 - 3/8 nylon lock nuts

Find the cable loops that come out of the top of the cradle.

These are raised through the tubes that are welded to the posts and held in place using:

- 5 - 1/2 x 2-1/2 hex bolts
- 5 - 1/2 nylon lock nuts

The loops that come out of the bent cradle tubes fasten closest to the post.

The two cables closest to posts #3 and #4 will be loose. These are leveling cables and will cause the lift to work improperly if they are tight. Do not be concerned by their looseness.

Find the one remaining loose end of cable and grease the last two feet of it. Find the wedge taped to the winch. Wrap the cable around the winch drum clockwise from the outside of the lift, and insert the end through the small end of the welded channel on the inside of the drum. Make a loop and push the end back through the welded channel. Insert the steel wedge into the center of the

bolt package step 7

1

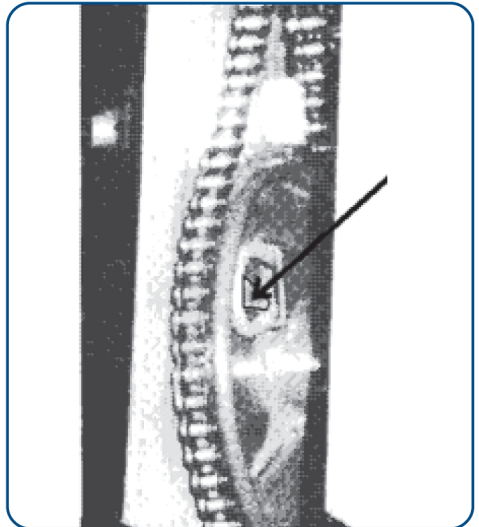
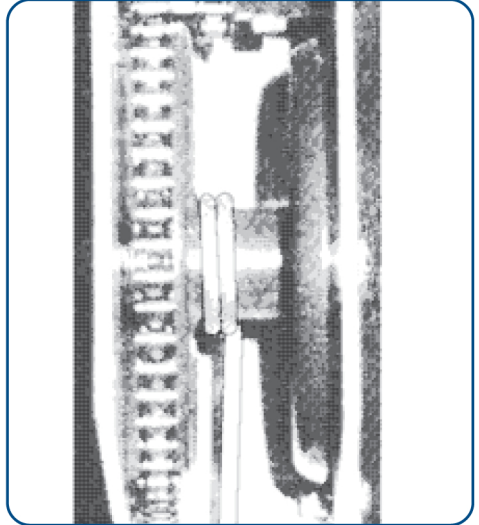

loop you just made with the cable and pull the cable tight. Wrapping the cable evenly will help prolong its life.

8. bunks

Attach the Bunk Sockets directly to the Front and Rear Cradle Assemblies using the Bunk Plates and

16 - 3/8 x 2-1/2 hex bolts

16 - 3/8 nylon lock nuts

The Sockets should be on the inside of the cradle. Do not tighten these now as they will need to be adjusted to fit your boat.

Slide the Carpeted Wood Bunks down into these sockets and fasten in place with:

4 - 3/8 x 2-1/2 clevis pins

4 - hairpin cotters

bunk sockets	4
bunk socket plates	4
bolt package step 8	1

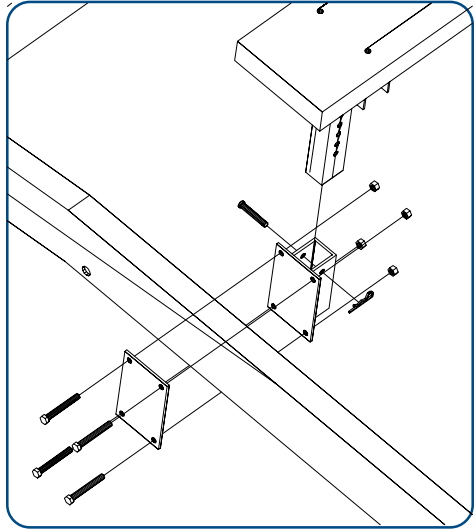

final touches

Place the Winch Cover on the winch.

Place the 3.5 x 3.5 red plastisol caps on the tops of the posts.

Place the 1.5 x 4.5 red plastisol caps on the welded stubs that the cables bolt to.

Move the lift to where it is to be used.

Adjust the leg height so that the lift is level. Do this by removing the clevis pin of the lowest leg, lifting that corner of the lift to level and replacing the clevis pin. Don't forget the hairpin cotter.

Adjust the positions of the Carpeted Wood Bunks to fit your boat.

3.5" x 3.5" red caps	4
1.5" x 4.5" red caps	3

CHECK YOUR LIFT

Raise and lower the cradle several times while looking for any problems. Now is a much better time to fix these than after the lift is in the water. Here are some general guidelines:

- 1-The cradle should move smoothly up and down.**
- 2-All cables should ride in pulleys.**
- 3-No two cables should cross outside of a tube.**
- 4-No cable should ride directly on a tube.**

IMPORTANT

Occasionally check the cables for fraying and make certain that all cables are riding properly. This will guarantee years of trouble-free operation.

When transporting the lift assembled, tie the cradle unit to the lower mainframe and use the winch to put tension on the cables. Once you've reached your destination, check that all of the cables are still riding in their pulleys.

At the beginning of each season, you should check your lift before entrusting your boat to it:

- Check that your winch turns easily without any weight on it.**
- Check that the braking mechanism works with weight on the lift.**
- Check your cables for fraying.**
- Check that your pulleys turn freely.**
- Check that the cables are riding in pulleys and not against aluminum.**

10/2 Year Limited Warranty

Lakeshore Products, Inc. (Seller) warrants the aluminum structure on docks and lifts of its manufacture to be free from defects caused by faulty material or poor workmanship. Seller will, at its option, repair or replace any such goods found on examination by Seller, to be defective under normal use and service within ten years from date of purchase. Upon discovery of any such defect, Buyer must notify Seller in writing of defect and provide proof of purchase. Seller warrants cast aluminum parts, mechanical components, and hardware for two years.

Seller shall not be held responsible for repairs or modifications to its docks or lifts unless authorization has been obtained from Seller. This warranty does not cover damage caused by incorrect assembly or adjustments, overloading, improper use, neglected maintenance, alterations, or damage caused by accident, ice, salt water, or acts of God.

Components obtained from other manufacturers and used in Seller's products will be covered under the manufacturer's warranty and shall not be the responsibility of the Seller.

Seller's responsibility under this warranty shall be the repair or replacement of defective items. Seller is not liable for incidental or consequential damages of any kind.

Your Waterfront Specialists

855 Chicago Road • Quincy, Michigan 49082
tel 517.639.3815 • fax 517.639.4576