



Owner's Manual

LSV20100C

2000 lb, 100" Beam Vertical Lift

LSV20100C

- LS5000B leg bundle
- LS5001B post bundle
- LS1502C cradle bundle
- LS1503C spreader bundle
- LS5004B bunk bundle
- LS1505B accessory box
- LS2005B wheel

READ CAREFULLY - FAILURE TO FOLLOW INSTRUCTIONS AND SAFETY RULES MAY RESULT IN SERIOUS INJURY



▲ WARNING

DO NOT ATTEMPT TO STOP SPINNING WHEEL.
Serious personal injury could result.

Lift Wheel must be turned clockwise for lifting.
NEVER raise lift by turning wheel counterclockwise.
Doing so will result in an uncontrolled spin down,
which could lead to cable failure and serious injury.

Z117

▲ CAUTION

DO NOT CRANK PAST STOP POSITION.

When raising lift be aware that when moving components contact frame you have reached maximum height.
Turning wheel past this point may cause personal injury and will cause damage to lift that is not covered by warranty.

Z119

▲ WARNING

DO NOT OPERATE THIS HOIST WITHOUT FIRST STUDYING THE OWNER'S MANUAL.

1. Before operating this lift be sure to understand all operating procedures and safety precautions.
2. **NEVER** operate lift with people on board boat or near any part of lift.
3. **NEVER** work or play on, around or under lift.
4. **NEVER** exceed the rated capacity of lift. Doing so may cause lift to fail.
5. Before use visually inspect **SHEAVES** and **CABLE** for wear or fraying. Follow proper maintenance procedures.

Failure to follow these procedures could cause lift to fail and result in death or serious personal injury.

Z116

Manufacturers of Lakeshore Products

855 East Chicago Road, Quincy, MI 49082

www.lakeshoreproducts.com • tel: 517.639.3815 • fax: 517.639.4576

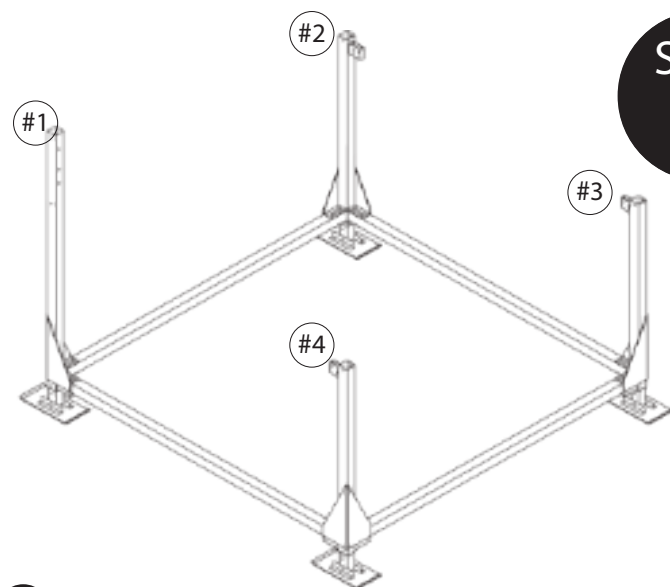

STEP 1

PARTS FOR THIS STEP	
MAINFRAME POSTS (A,B,P,R)*	4
LEGS (S,T)	4
SIDE MAINFRAME SPREADERS (O)	2
F/R MAINFRAME SPREADERS (W)	2
BOLT PACKAGE STEP 1	1

* denotes letter on exploded view

1.1 attach LEGS

Slide 4 LEGS into the 4 MAINFRAME POSTS using:

- 4 - 3/8" x 4" bent clevis pins
- 4 - hairpin cotters

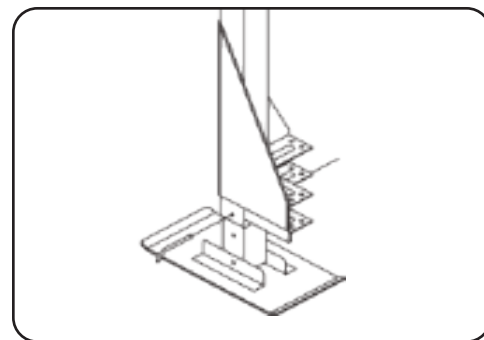

1.2 arrange MAINFRAME POSTS

Stand all 3 shorter MAINFRAME POSTS on a flat area, arranged as shown above.

1.3 attach SIDE MAINFRAME SPREADER tubes

Position one SIDE MAINFRAME SPREADER tube between POST #1 and #4. The SIDE MAINFRAME SPREADER tubes are 120" long with the large slots in each end.

Bolt in place using:

- 2 - 3/8" x 5" hex bolts
- 4 - 3/8" flat washers
- 2 - 3/8" nylon lock nuts

at each POST. Repeat with other SIDE MAINFRAME SPREADER between POST #2 and #3.

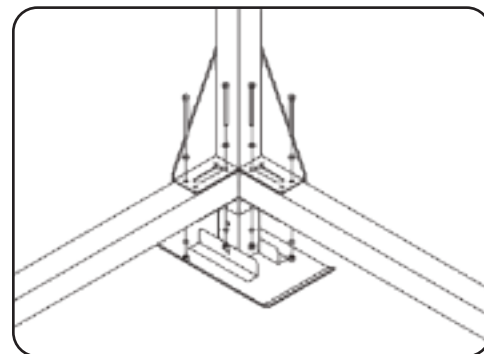

1.4 attach FRONT/REAR MAINFRAME SPREADER tubes

Position one F/R MAINFRAME SPREADER tube between POST #1 and #2. This is the front of the lift. Bolt in place using:

- 2 - 3/8" x 5" hex bolts
- 4 - 3/8" flat washers
- 2 - 3/8" nylon lock nuts

at each POST. Repeat with other F/R MAINFRAME SPREADER between POST #3 and #4. This is the rear of the lift.

NOTE: On the 30108 and 40108 models the F/R MAINFRAME SPREADERS are 108". On the 30120 and 40120 models the F/R MAINFRAME SPREADERS are 120".

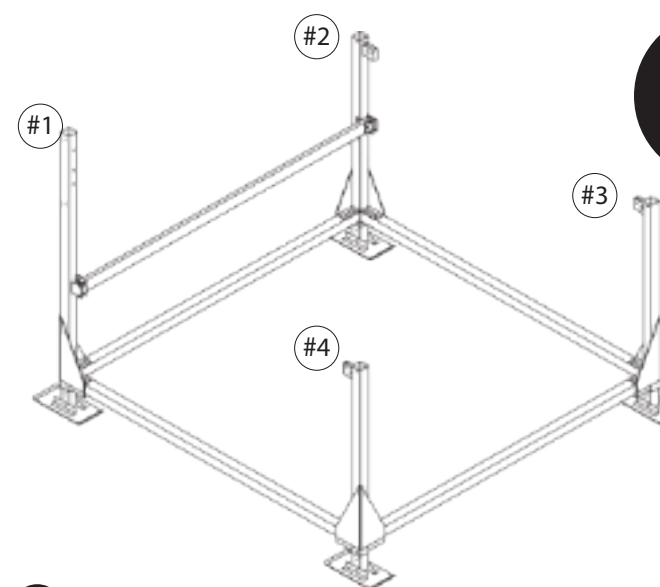

STEP 2

PARTS FOR THIS STEP	
FRONT CRADLE (L)	1
WINCH WITH ADAPTER (H, I)	1
WHEEL 41" (J)	1
BOLT PACKAGE STEP 2	1

2.1 attach WINCH

Remove the three screws that hold on the WINCH cover. Lay POST #1 on its side and attach winch using:

- 2 - 3/8 x 5" hex bolts
- 2 - large aluminum washers
- 2 - 3/8 nylon lock nuts

Be sure to place the washers under the heads of the bolts on the outside of the post. Stand POST #1 up and bolt to the MAINFRAME SPREADER TUBES as described in Steps 1.3 and 1.4. Be sure to place the washers under the heads of the bolts on the outside of the post.

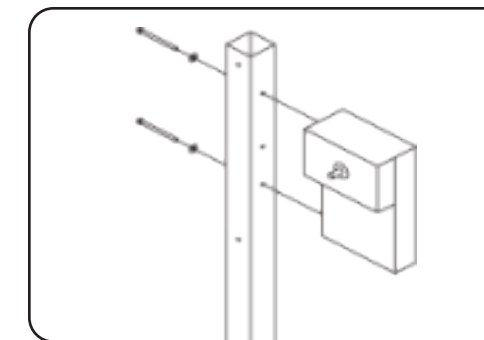

2.2 attach WHEEL

Remove the 4 carriage bolts from the wheel mounting plate. Align the 4 holes in the mounting plate with the holes on the SHAFT ADAPTER.

Attach using the 4 carriage bolts and locknuts provided.

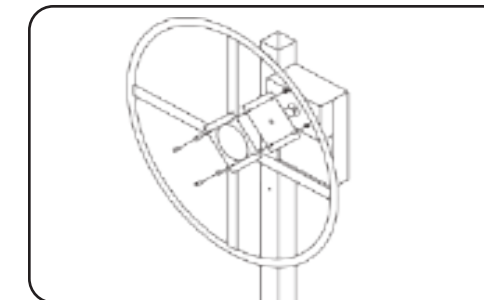

2.3 attach FRONT CRADLE

Position the FRONT CRADLE between POST #1 and #2.

NOTE: the FRONT CRADLE has a cable with a loop on only one end.

Attach the loop end to POST #2 in the low hole closest to the POST with:

- 1 - 1/2" x 2-1/4" hex bolts
- 1 - 1/2" nylon lock nuts

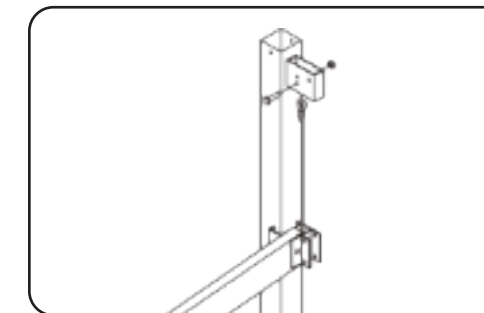

2.4 attach CABLE

The cable attaches to the black drum at the bottom of the WINCH. It passes through the hole in this drum and is held in place by a set screw located in the center of the hole. The head of this screw can be reached through a hole that has been placed on the side of the WINCH. The drum will have to be turned until the set screw appears through this hole. Loosen the screw with the 5/32" allen wrench supplied with your lift. Then pass the cable through the hole in the drum until 1/4" of the cable sticks out the other end, and tighten the set screw.

NOTE

The wheel needs to thread on and off the shaft to activate the brake. This shaft should be greased yearly to ensure proper operation.

Extreme care should be taken not to cross thread and damage the threads on the wheel hub. This will void your warranty.

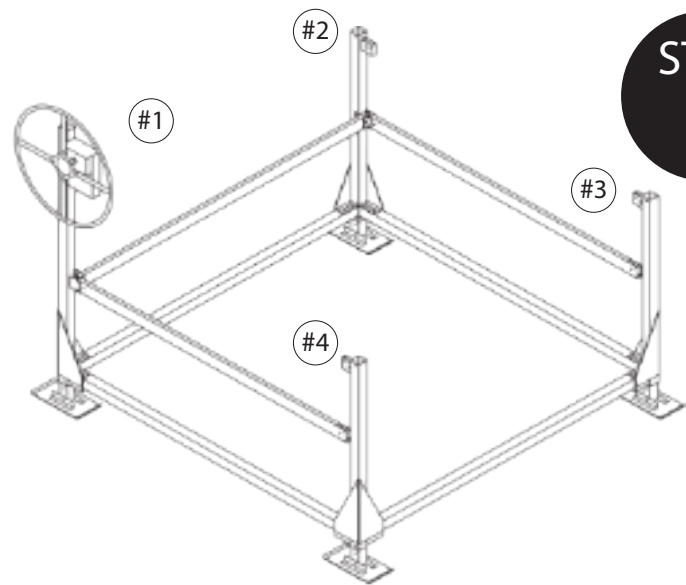

STEP 3

PARTS FOR THIS STEP	
CRADLE SPREADERS (M)	2
BOLT PACKAGE STEP 3	1

3.1 attach CRADLE SPREADER

Attach one end of the **CRADLE SPREADER** tube to the **FRONT CRADLE** near **POST #1**. Use:

- 4 - 3/8" x 2-1/2" hex bolts
- 4 - 3/8" nylon lock nuts

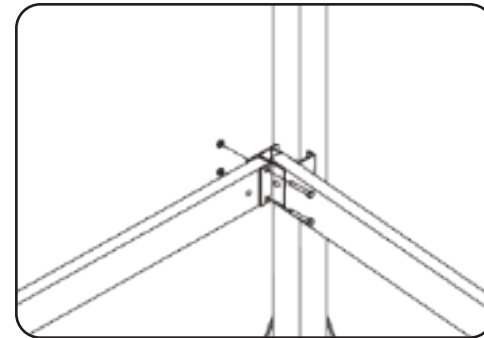

3.2 attach SIDE CABLE

Feed the end of the **CABLE** that hangs down through the holes in the **MAINFRAME SPREADER** tube by **POST #1** and pull out the bottom of the lift. Using:

- 1 - shackle

Unscrew the shackle pin and put the shackle through the loop at the end of the **CABLE**. Securely thread the pin into the shackle and tighten to secure the **CABLE**.

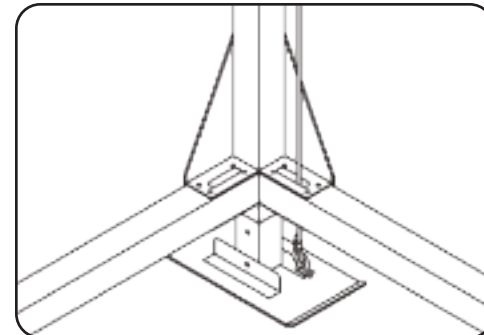

3.3 attach SIDE CABLE

Take the opposite end of the cable that comes up out of the **SPREADER** and attach it to the top of **POST #4**. Use the holes furthest away from the **POST** and attach using:

- 1 - 1/2" x 2-1/4" hex bolt
- 1 - 1/2" nylon lock nut

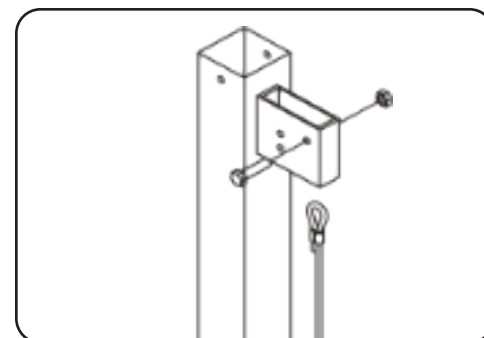

3.4 repeat

Repeat for other **CRADLE SPREADER**.

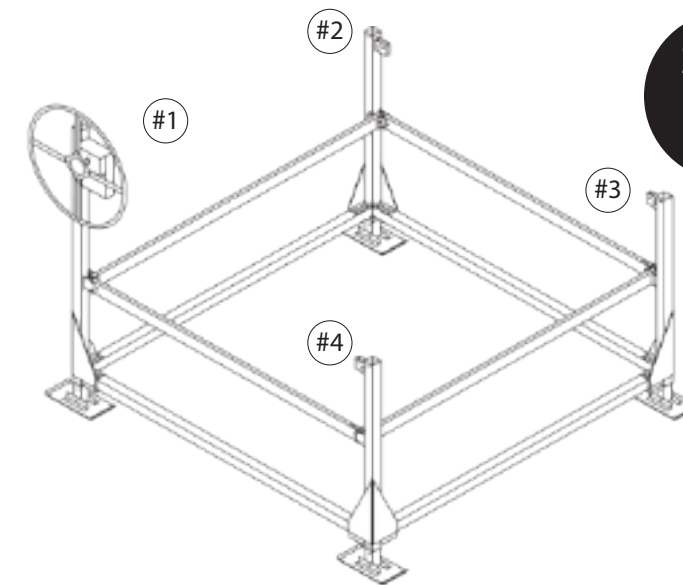

STEP 4

PARTS FOR THIS STEP	
REAR CRADLE (Q)	1
BOLT PACKAGE STEP 4	1

4.1 attach REAR CRADLE

Set the **REAR CRADLE** on the ends of the **CRADLE SPREADER** tubes. Attach to the **SPREADERS** using:

- 2 - 3/8" x 2-1/2" hex bolts
- 2 - 3/8" nylon lock nuts

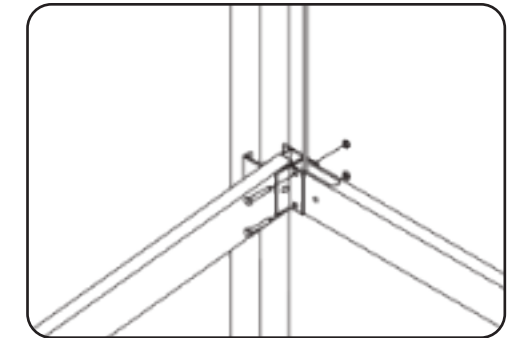

4.2 attach CABLES at bottom

Feed the two down cable ends through the side **MAINFRAME SPREADER** tubes and out the bottom of the lift. Attach using:

- 2 - shackles

Unscrew the shackle pin and put the shackle through the loop at the end of the **CABLE**. Securely thread the pin into the shackle and tighten to secure the **CABLE**.

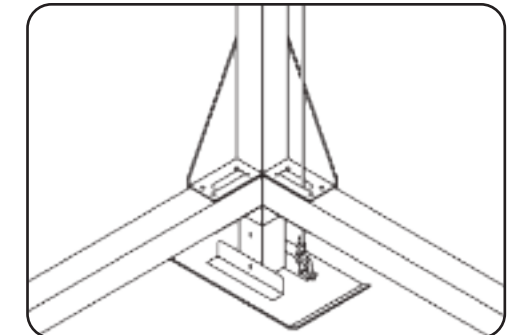

4.3 attach CABLES at top

Attach the two up ends of the **CABLES** to **POST #3** and **#4**. Use the holes closest to the **POST**, starting with both **CABLES** in the lowest holes. If the rear **CABLES** appear too loose, try moving one **CABLE**, or both to the next hole. Bolt in place using:

- 1 - 1/2" x 2-1/4" hex bolt
- 1 - 1/2" nylon lock nut

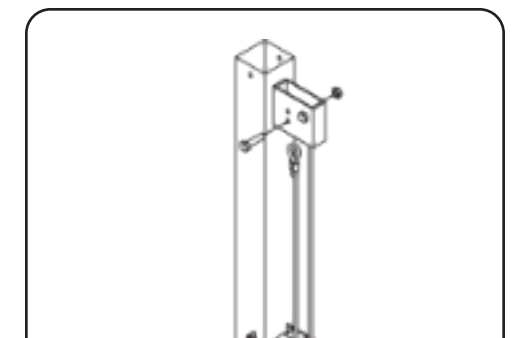

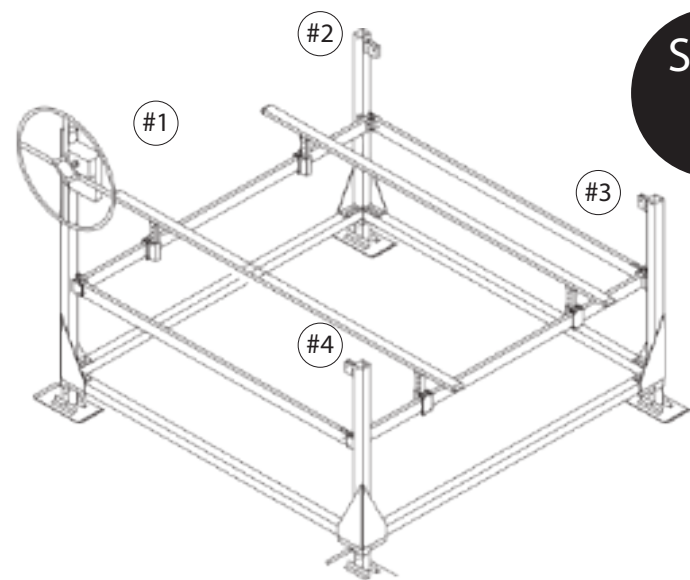

STEP 5

● PARTS FOR THIS STEP

BUNK ASSEMBLY (C)	2
BUNK SOCKET / ASSEMBLY (F/J)	4
BOLT PACKAGE STEP 5	1

5.1 attach BUNKS

Attach **BUNK SOCKETS** and **BUNK SOCKET PLATES** making sure to place the sockets towards the inside of the lift using:

- 16 – 3/8" x 2-1/2" hex bolts
- 16 – 3/8" nylon lock nuts

Install the **BUNKS** by sliding into the **BUNK SOCKETS** and securing with:

- 4 – 3/8" x 2-1/2" clevis pins
- 4 – hairpin cotters

5.2 adjust BUNKS

Move your lift into the water.

Adjust the height and position of the **BUNKS** so that they cradle your boat and keep the bottom of the boat off the **CRADLE**.

5.3 adjust LEGS

Adjust the lift **LEGS** so that the lift sits level in the water, within 3" to 6" is acceptable.

LS1505B accessory package

BPV30BSS	Bolt Package V30/40B	1
W5	Winch 3500 lb. w/adaptor	1
20676	Bunk Socket	4
20678	Bunk Socket Plate	4
CAPS3535	3 1/2" x 3 1/2" Black Cap	4

BPV30BSS bolt package

20848SS	STEP 1	
X420	3/8" x 5" hex bolt	16
Z451	3/8" hex lock nut	16
X452	3/8" flat washer	32
CP1	3/8" x 4" bent clevis pin	4
HPC	1/8" hairpin cotter	4
20849SS	STEP 2	
X420	3/8" x 5" hex bolt	2
Z451	3/8" hex lock nut	2
X509	1/2" x 2-1/4" hex bolt	1
Z551	1/2" hex lock nut	1
20981	large aluminum washer	2
20890	5/32 allen wrench	1
20850SS	STEP 3	
X410	3/8" x 2 1/2" hex bolt	4
Z451	3/8" hex lock nut	4
X509	1/2" x 2-1/4" hex bolt	2
Z551	1/2" hex lock nut	2
SHACKLE	3/8" shackle	2
20851SS	STEP 4	
X410	3/8" x 2 1/2" hex bolt	4
Z451	3/8" hex lock nut	4
X509	1/2" x 2-1/4" hex bolt	2
Z551	1/2" hex lock nut	2
SHACKLE	3/8" shackle	2
20852SS	STEP 5	
X410	3/8" x 2 1/2" hex bolt	16
Z451	3/8" hex lock nut	16
CP	3/8" x 2 1/2" clevis pin	4
HPC	1/8" hairpin cotter	4

hints

- A. Shallow water? Remove the adjustable legs to make the lift sit even lower in the water. In this position the Cradle can be placed lower than on any other lift available.
- B. Deep water? Extension legs are available in 4', 5', and 6' lengths. Call your Dealer for pricing.
- C. The front Cable will last much longer if you grease the first 5' to 8' that goes into the winch.
- D. The winch and brake mechanism will work better if the wheel shaft is greased yearly. This task has been simplified by the addition of a grease fitting on the wheel shaft right behind the red wheel.
- E. Do not over crank your lift. Be sure to notice the maximum height that your lift will rise to and STOP when you reach that height. Failure to do so will damage your lift.

important

- A. Grease the winch shaft annually. The red wheel must be able to thread and unthread easily in order for the braking mechanism to work properly.
- B. Your Lakeshore Lift will only protect your personal watercraft if the craft is lifted well above the level of the water. In larger lakes or during storms, large waves may lift the craft from the lift or tip the lift over, causing damage both to the craft and the lift. You must take precautions to protect your craft and lift from these conditions. If your craft suffers damage from high waves, LSP, Inc. will not accept responsibility for such damage.
- C. Inspect your lift often for signs of wear or improper operation. Be aware of normal cranking force. Any increase in cranking force is a sign that something is wrong. DO NOT USE the lift if any parts are worn or damaged, replace immediately.
- D. Pay attention to the condition of your cable. A frayed or rusted cable can lead to failure of the lift. Replace it immediately. Greasing the cable, especially where it enters the winch, can extend its life.
- E. A second caution decal is provided in the accessories box. If after assembly the decal is not easily seen then install the extra decal so that anyone using the lift can read it. NEVER let anyone operate the lift unless they are familiar with all safety rules.
- F. NEVER let anyone play on, around, or under the lift.

25/2 Year Limited Warranty

Effective for all products purchased after January 1, 2026

Twenty Five Years on Aluminum Structure We (LSP, LLC) warrant the aluminum structure on the docks and lifts that we manufacture to be free from defects caused by material or workmanship for twenty five years from the date of purchase.

Two Years on Components We warrant all other materials including cast aluminum parts, mechanical components, hardware, canopy covers, cables, bunks, etc. for two years.

Other Manufacturers' Parts Any components obtained from other manufacturers for use in our products are covered under the original manufacturer's warranty by the original manufacturer. We will support the resolution of any failures of these parts, but do not warrant them ourselves.

Defective Part? Should you discover a defect in one of our products, contact the dealer you purchased the product from. If you need to find a local dealer, use the Dealer Locator on our website or contact us directly at lakeshoreproducts.com.

What will we do? Working through your local dealer, we will repair or replace any parts or components that we determine to be defective under normal use and service. The dealer will perform the exchange of parts and any labor that may be necessary.

Legal Stuff

Our responsibility under this warranty is limited to the repair or replacement of defective items and does not include incidental or consequential damages of any kind. We are not responsible for failures or damage due to repairs or modifications to our products that we have not previously approved; incorrect assembly or adjustment, overloading, improper use, neglected maintenance; or resulting from an accident, environmental factors (chemicals, tree sap, salt, etc.), extreme weather, or natural disasters (rainstorms, windstorms, tornadoes, etc.).

LSV20100C Vertical Boat Lift, 2000 lbs. Capacity, 100" Beam Width, 54" Lift Height.

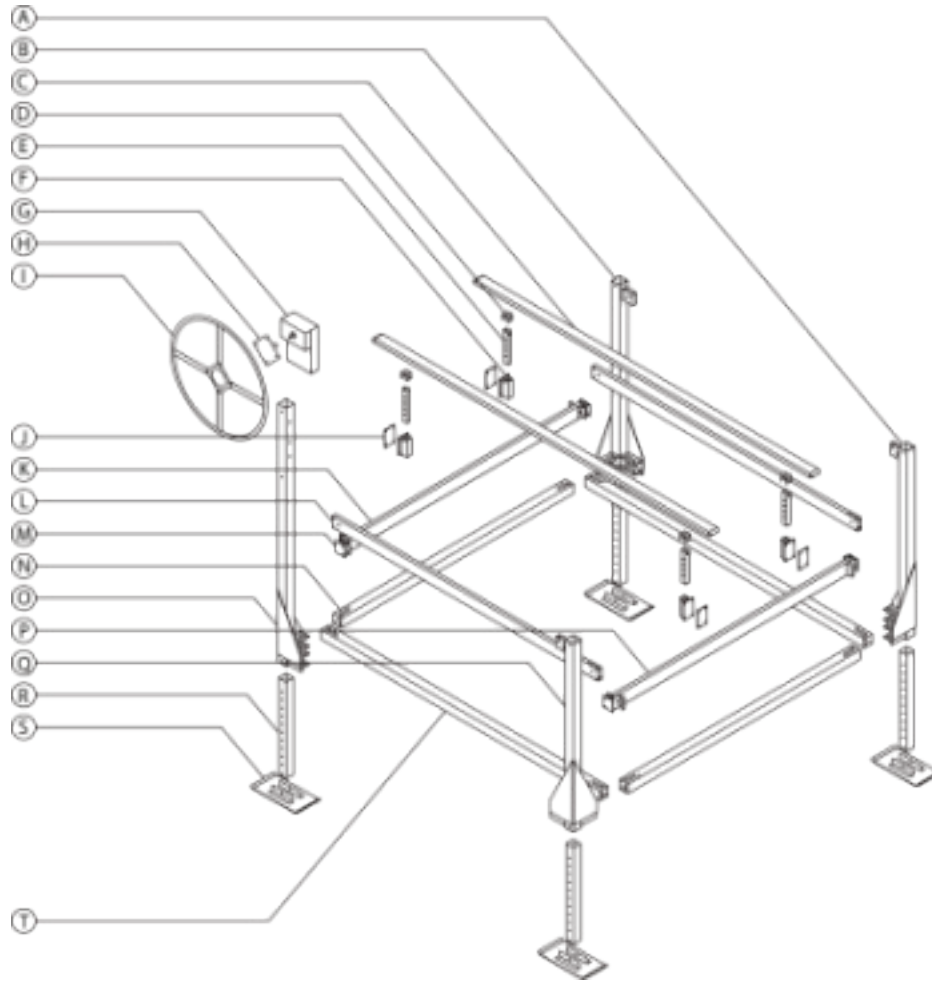

PARTS LIST LSV20100C

REF.	PART NO.	PART NAME	QTY.
A	20834	Mainframe Post #3	1
B	20833	Mainframe Post #2	1
C	BUNKAV	Bunk Assembly	2
D	21026	Bunk Channel	4
E	BDL12	Bunk Down Leg	4
F	20676	Bunk Socket	4
G	W5	3500 lb. Winch	1
H	20886	Shaft Adapter	1
I	LS2005B	41" Wheel	1
J	20678	Bunk Socket Plate	4
K	21043	Cradle Front	1
L	21041	Cradle Spreader	2
M	21035	Cradle Corner Bracket	4
N	20879	Mainframe Spreader 100"	2
O	20832	Mainframe Post #1	1
P	21043	Cradle Rear	1
Q	20833	Mainframe Post #4	1
R	20989	Leg Tube 36"	4
S	20990	Foot Pad	4
T	20879	Mainframe Spreader 100"	2

REPLACEMENT PARTS

PART NO.	PART NAME	QTY.
20856SS	Cable Front 108B I 5/16" x 258" SS	1
20881	Cable Side 100B M 1/4" x 161" SS	2
20882	Cable Rear 100B N 1/4" x 171" SS	2